



R O L L I N G S T E E L D O O R S

4255 McEver Industrial Drive
Acworth, Georgia 30101
Phone: (770) 974-2600 Toll Free: (800) 423-0659
Fax: (770) 974-1455

Installation Instructions

Models: CS544 - CS522 & CS566
Counter Shutter

Tension Side View

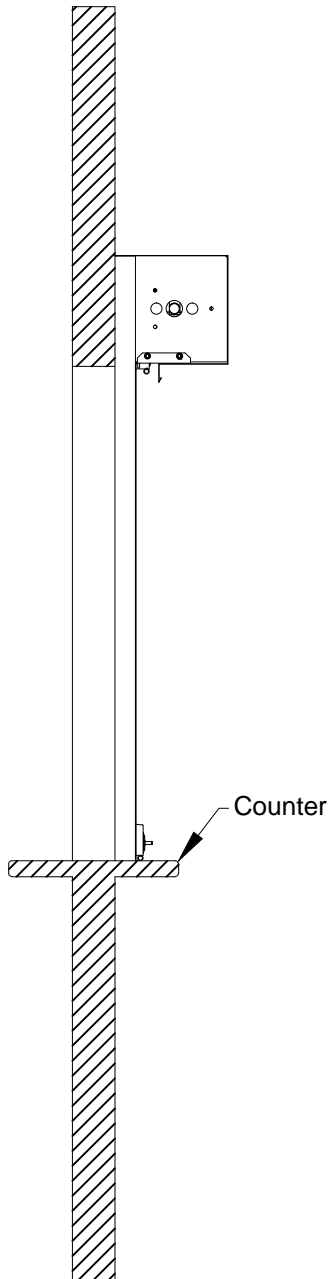

Front View

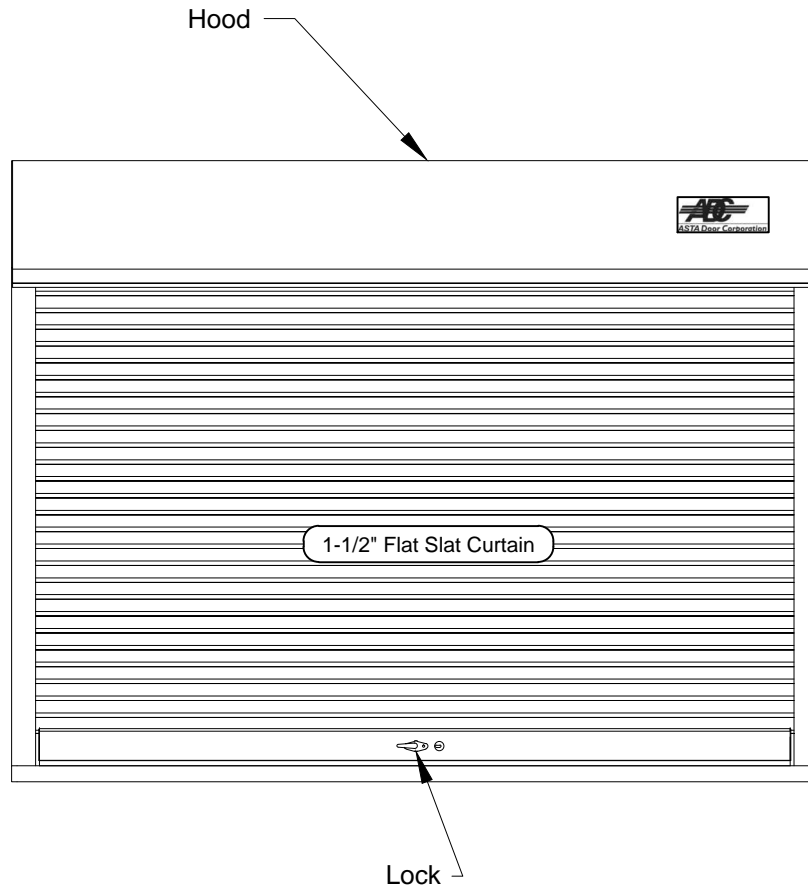

Drive Side View

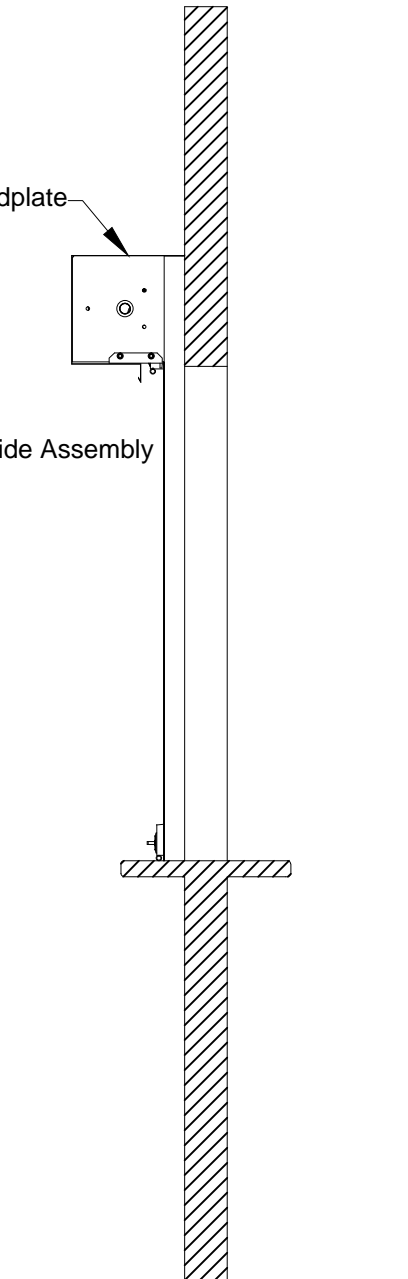

Counter Shutter Basics



Guide Basics

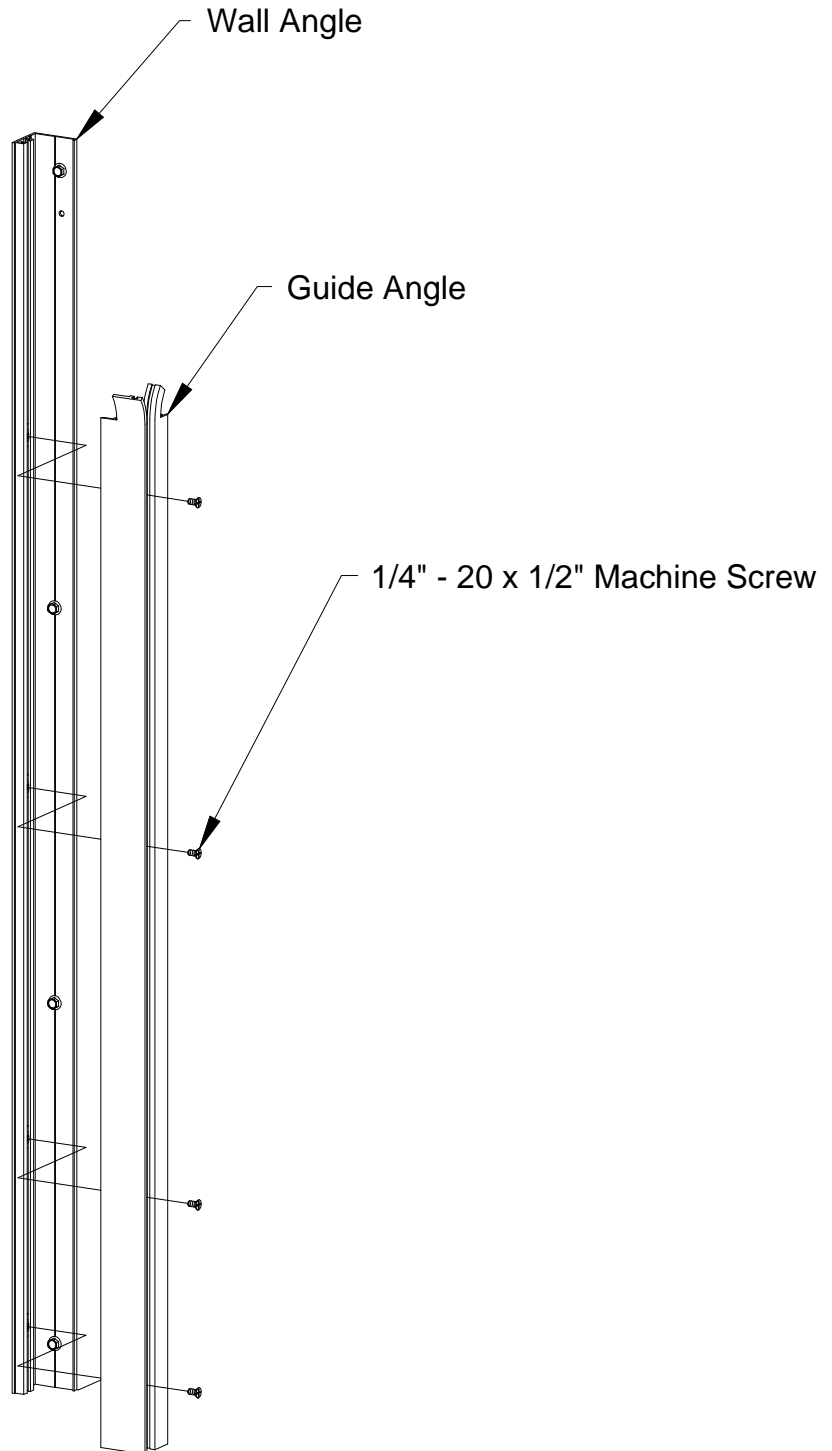

TABLE OF CONTENTS

Counter Shutter Basics

Guide Basics

Sections:	1.0	General	Page	1
	2.0	Shipment Inspection	Page	1
	3.0	Checking Shutter Requirements	Page	1
	4.0	Existing Conditions	Page	1
	5.0	Preparation	Page	1
Section:	6.0	Guide Installation	Pages	2-4
Section:	7.0	Head Plate and Barrel Identification	Page	5
Section:	8.0	Head Plate and Barrel Assembly Installation	Pages	6-8
Section:	9.0	Optional Awning Crank Assembly	Page	9
Section:	10.0	Curtain Installation	Page	10
Section:	11.0	Guide Assembly	Page	11
Section:	12.0	Curtain Stop Assembly	Page	11
Section:	13.0	Tensioning the Barrel	Pages	12-13
Section:	14.0	Hood Installation	Page	14
Section:	15.0	Maintenance	Page	15
Section:	16.0	Painting Instructions	Page	16
		Troubleshooting	Page	17

ASTA ROLLING COUNTER SHUTTER INSTALLATION INSTRUCTIONS

These instructions will show you how to install a ASTA Rolling Counter Shutter. They are for the mechanically experienced person who has proper tools to perform the job. They are not meant to infringe upon or supersede any State or County building codes or safety regulations.

Safety first. Safety warnings are clearly marked with a ⚠ **WARNING!!** symbol throughout and are displayed in their entirety on page 15. Critical information is identified by a ⚡ **CRITICAL!** symbol. Tips are marked with a 💡 symbol. Observe all guidelines, warnings, tips and critical information given in the instructions during installation.

1.0 GENERAL: Read and familiarize yourself with this entire manual before proceeding with installation. Contact ASTA for technical information at 4255 McEver Industrial Drive Acworth, Georgia 30101. Toll Free:(800) 423-0659

2.0 SHIPMENT INSPECTION: When the shipment arrives check for freight damage and missing items. Use packing list to determine completeness of shipment. If there is damage or a shortage is detected, contact ASTA immediately.

3.0 CHECK SHUTTER REQUIREMENTS: Use shop drawing to verify the following:

- ✓ Width of opening
- ✓ Height of opening
- ✓ Headroom
- ✓ Side room

4.0 EXISTING CONDITIONS:

- ✓ Is counter level?
- ✓ Is header level?
- ✓ Are jambs plumb?

4.1 Inspect jambs and adjacent wall construction to verify that they are suitable for anchoring shutter angle assemblies. ASTA is not responsible for the structural soundness of existing jambs and adjacent wall construction.

✓ **WARNING!!** If in doubt of the fitness or structural integrity of jambs, a qualified engineer must inspect the existing conditions before proceeding further.

✓ **WARNING!!** Guides are not intended or designed to act as structural reinforcement for existing jambs.

✓ **WARNING!!** Installation of anchoring devices into unsound building material will result in product damage, personal injury, premature wear and product failure.

✓ **WARNING!!** Wear protective gloves and eye wear when working on the door.

5.0 PREPARATION:

5.1 Clean and sweep work area of any debris or objects that may interfere with installation. Place guide angles, wall angles and curtain on protective cardboard if possible.

5.2 Position all components on the floor in the approximate location they will be later assembled. Double check for completeness of shipment at this point.

6.0 GUIDE INSTALLATION: Fasteners for wall angles are supplied by ASTA for wood, steel and solid masonry jambs.

STEEL JAMBS

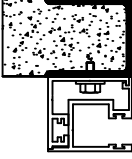
DETAIL VIEW	FASTENER
	<p>1/4" X 1" Hex Head Self Drilling Screw</p>

SOLID MASONRY

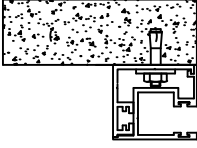
DETAIL VIEW	FASTENER	DRILL SIZE
	<p>1/4" Sleeve Anchor and Washer</p>	<p>1/4" Dia.</p>

SHEETROCK JAMBS

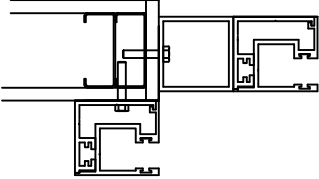
DETAIL VIEW	FASTENER	
	STEEL STUD	WOOD STUD
		<p>1-3/8" x 3-5/8" x 14 gauge minimum</p>
<p>1/4" x 2" Hex Head Self Drilling Screw</p>		<p>Drill 1/8" Pilot Hole 1/4" x 3" Hex Head Lag Screw and Washer</p>

6.1 Guides are shipped assembled and consist of a wall angle and a guide angle.

💡 Accurate Guide Installation: Mark a level reference point on each jamb to insure wall angles are installed level with each other. Measure from the reference marks on each jamb to the counter to achieve identical elevations. Set wall angles.

6.2 Face Mounted Standard Guides: Mark center of opening width on counter. Measure 1/2 "X" dimension (shown on shop drawing). This establishes outside face of wall angle.

⚡ **CRITICAL!** Actual opening width and height must equal dimensions shown on shop drawings supplied with this order. Contact ASTA immediately if dimensions do not match.

⚡ **CRITICAL!** The "X" Dimension is essential for proper door operation, and must be held constant from top to bottom.

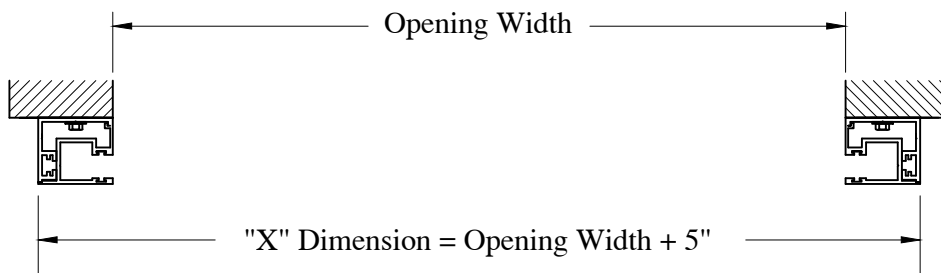

Standard Guide Clearances

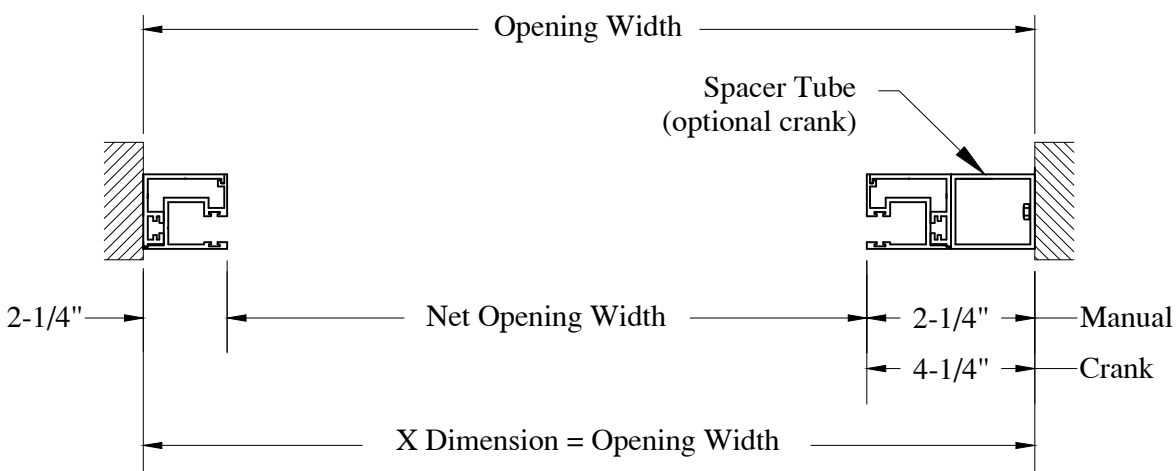

Between-Jamb Guide Clearances

- 6.3 Check the counter for slope. The counter should be level across the entire opening including required sidespace for mounting the guide assemblies.
- 6.4 Position wall angles on counter surfaces so they are plumb. Verify proper "X" dimensions at the top and bottom.
- 6.5 Fasteners for mounting angles are supplied by ASTA for wood, steel, and solid masonry. Refer to page 2 for proper size and type.
- 6.6 Two holes at the top of each wall angle are factory drilled for attachment to header. Drill a clearance hole 4" from bottom of wall angle. Continue to drill holes every 24" for remaining door height.
- 6.7 Fasten wall angles to jamb.

 **Do not tighten fasteners until angle positions are re-verified.**

 **CRITICAL! The installed shutter will not operate properly unless wall angles are plumb and level with each other.**

 **CRITICAL! Carefully review all fastener locations and the "X" dimension. ASTA will not warranty any door that does not have guides set plumb and level with each other, or with incorrect spacing between guide faces.**

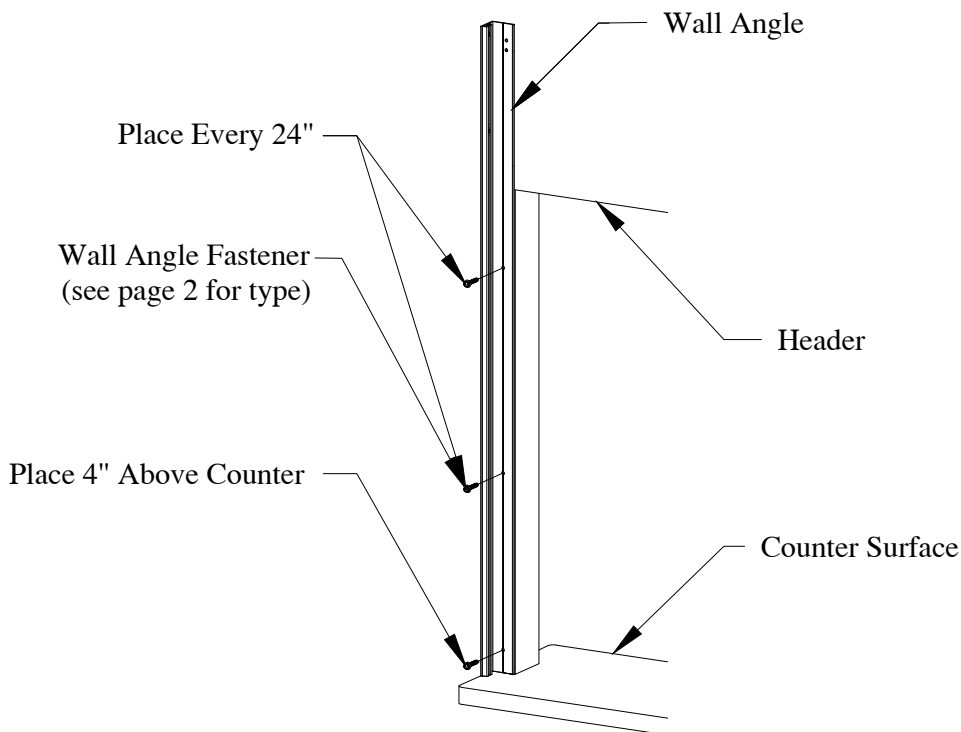

7.0 HEAD PLATE AND BARREL IDENTIFICATION:

7.1 Drive side and tension side head plates are nearly identical.

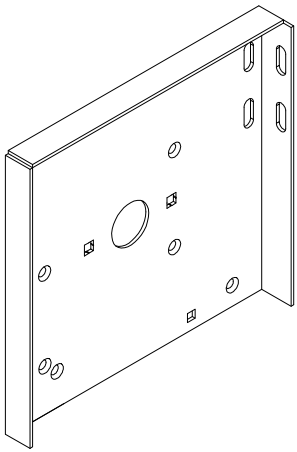

LH Head Plate

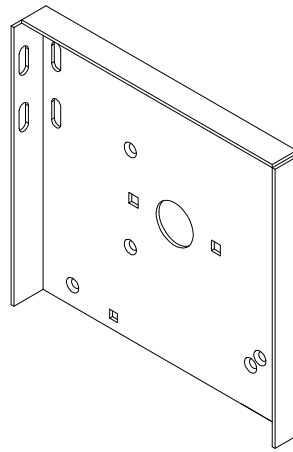

RH Head Plate

7.2 Barrel ends are identified by drive-side and tension-side.

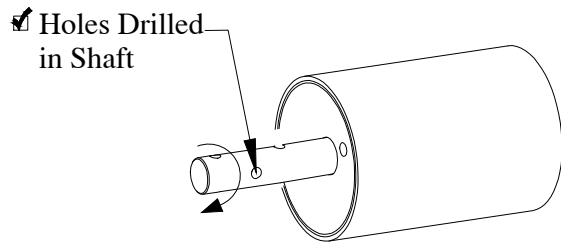

✓ Shaft Moves Freely

TENSION-SIDE

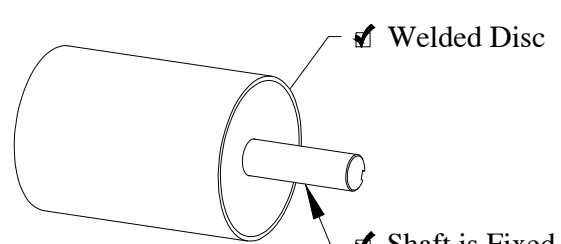

✓ Shaft is Fixed

DRIVE-SIDE

8.0 HEADPLATE AND BARREL ASSEMBLY INSTALLATION:

✓ **WARNING!!** Secure all loads to hoist equipment to prevent movement while hoisting. Do not allow personnel to ride hoist equipment. Stay off ladders and lifts until barrel and/or curtain have been hoisted to the final position of attachment. Serious personal injury will result from carelessness or lack of planning. Plan all moves carefully!

✓ **WARNING!!** It is essential that you use hoisting equipment of adequate stability and rated capacity to safely lift the barrel and head plate assemblies.

8.1 Install saddle bracket on tension side head plate (left side head plate shown) with two 5/16" x 3/4" carriage bolts and nuts.

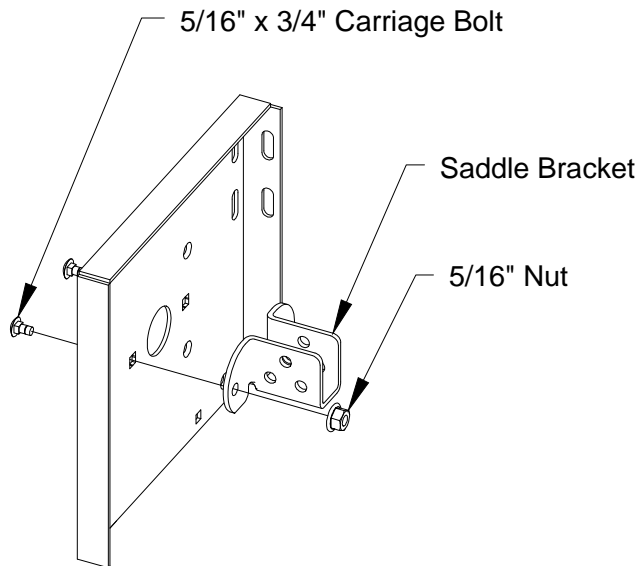

8.2 Fasten tension and drive head plates to wall angles with two 1/4" - 20 x 12" flat head machine screws.

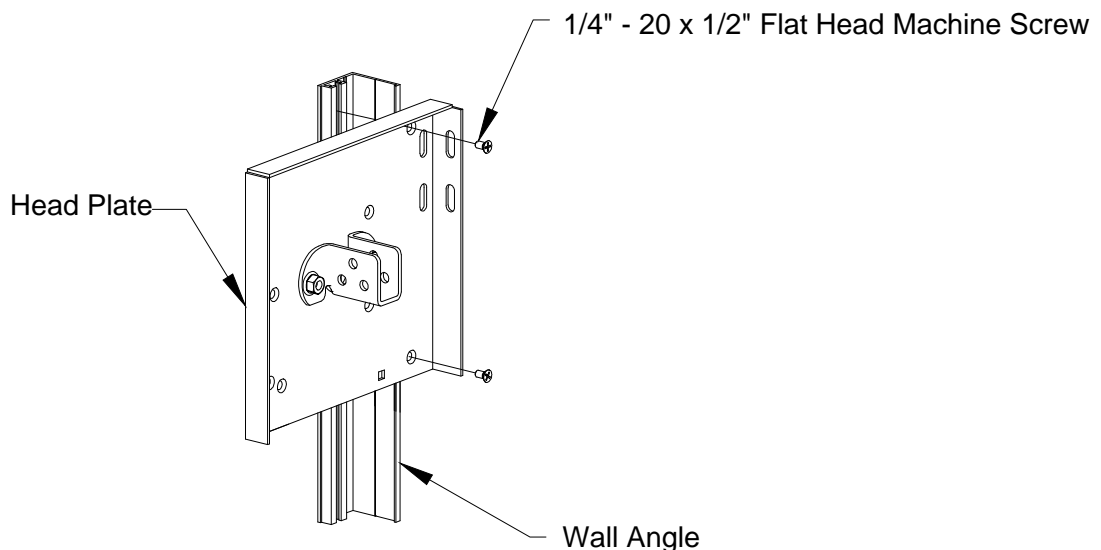

8.3 Position formed edge of hood retainer 1-3/4" down from top edge of head plates. Center retainer between head plates. Attach retainer to header with fasteners suitable for header material.

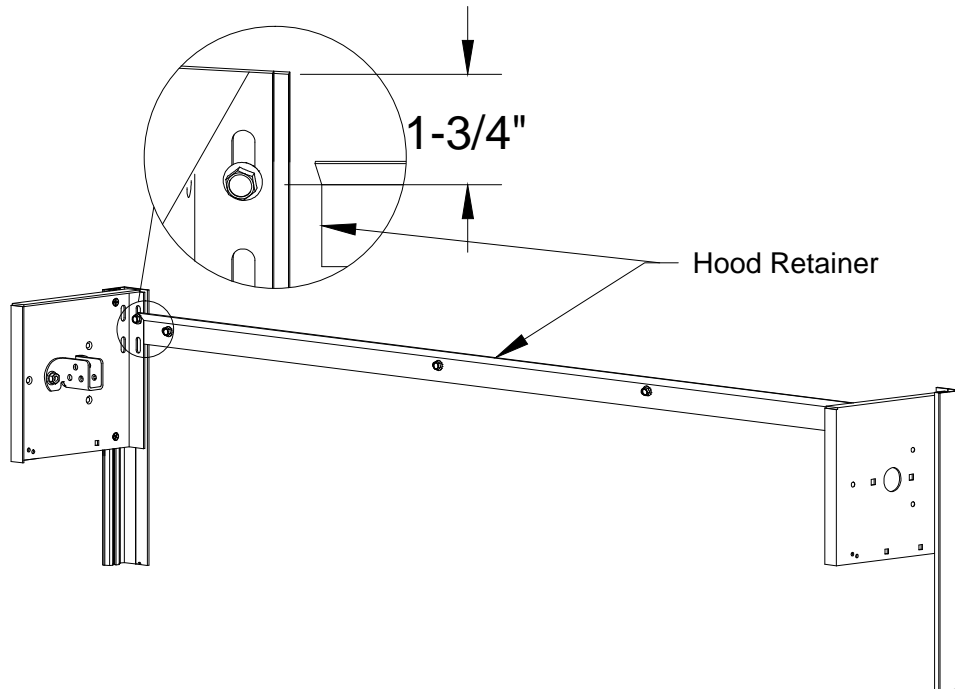

8.4 Once head plates are fastened to wall angles, slide two hole bearing onto barrel drive shaft and tension wheel onto barrel tension shaft.

 **NOTE: Two hole bearing is not required when using an awning crank.**

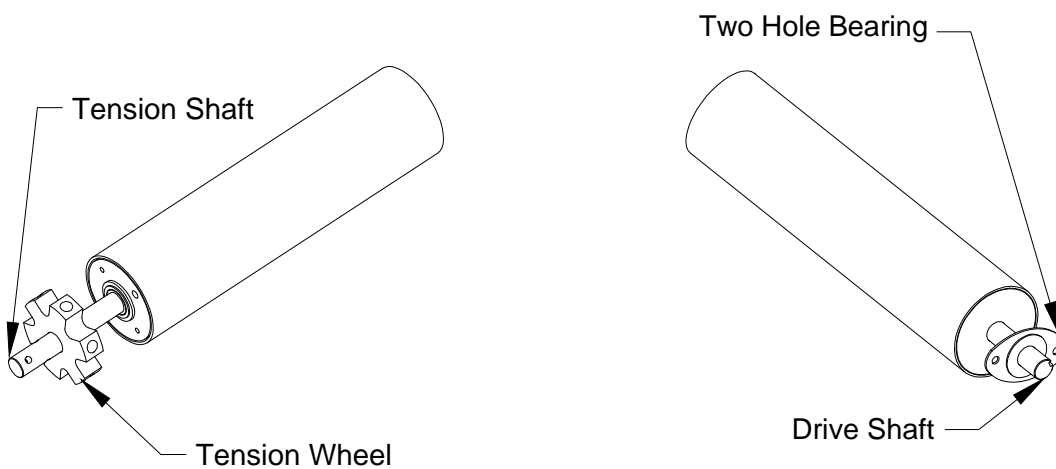

8.5 Carefully raise barrel to drive-side head plate at an angle. Insert drive shaft into hole in drive-side head plate. Rest tension-side shaft in saddle bracket.

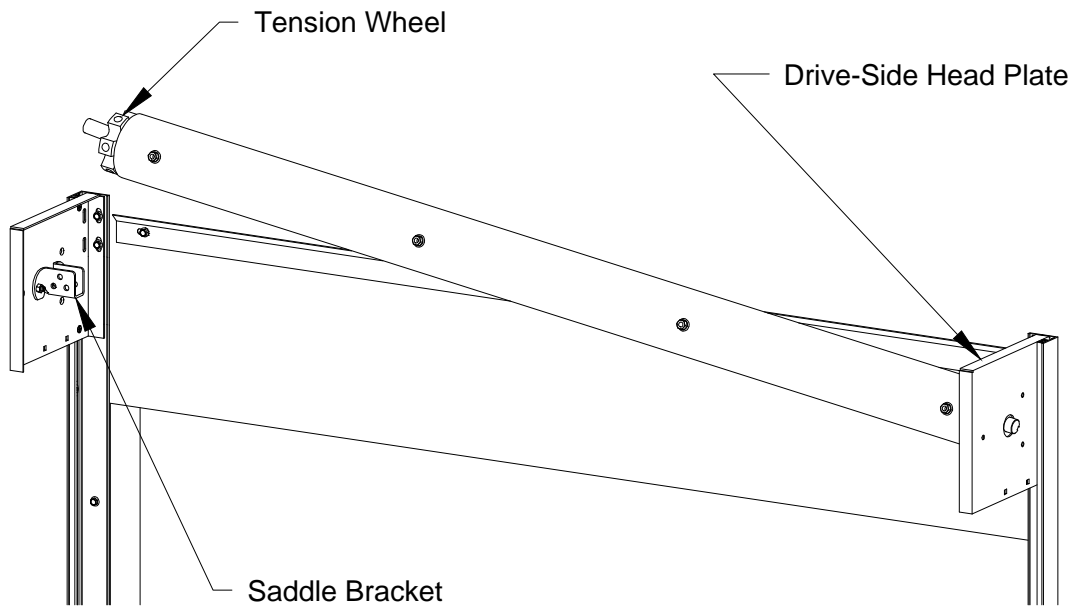

8.6 Fasten two hole bearing to drive-side head plate with two 5/16" x 3/4" carriage bolts and nuts.

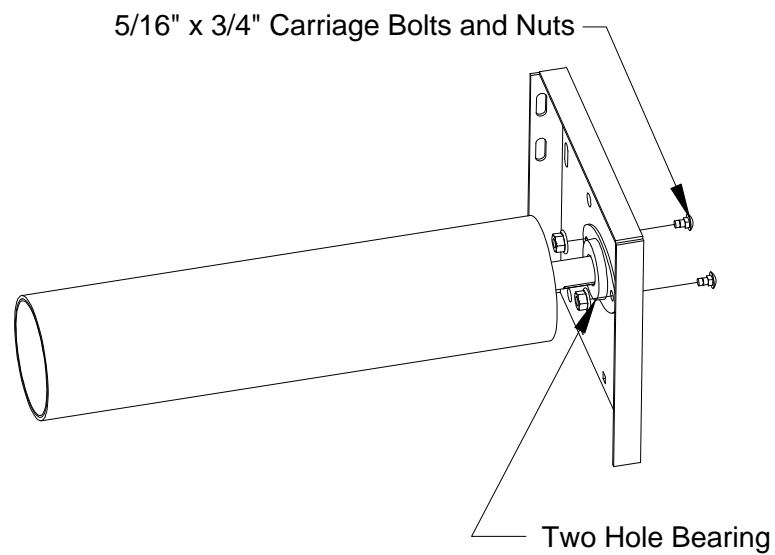

8.7 Check barrel rotation. Barrel should turn freely without binding.

⚡ **CRITICAL!** Do not proceed unless barrel is level and will rotate freely.

9.0 Optional Awning Crank Assembly: Slide 1" I.D. galvanized washer onto drive-side shaft followed by crank gear. Lubricate crank gear with grease. Align keyway in gear hub with keyway in shaft and insert key stock. Slide crank housing onto drive-shaft and fasten using three 1/4"-20 x 1" bolts and nuts.

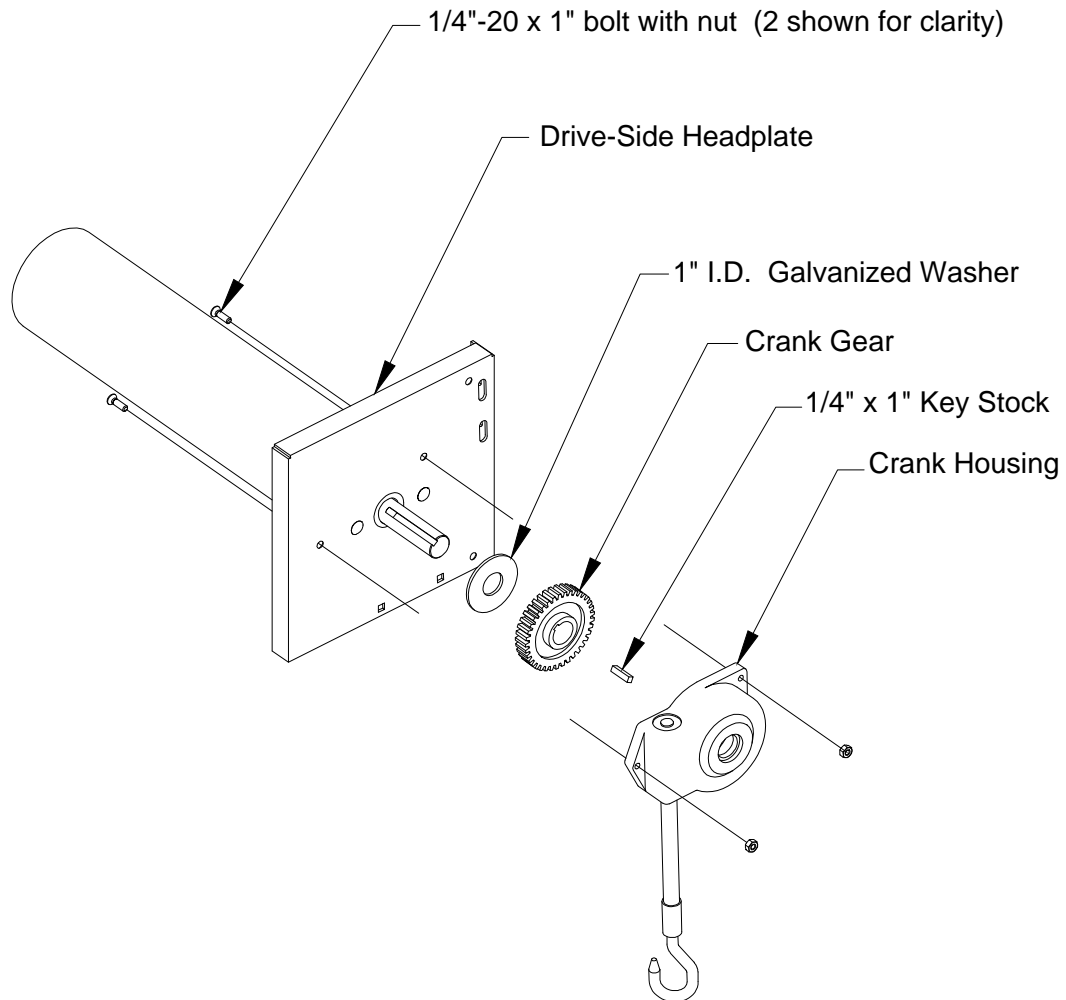

Optional Awning Crank Assembly

10.0 CURTAIN INSTALLATION:

💡 REMINDER: Before installing curtain, note number of turns of spring written on barrel and record that number in the space provided on page 12 section 13. After curtain installation spring barrel will be covered by curtain and turns of spring number written on barrel will no longer be visible.

10.1 Secure curtain and lift into place directly under barrel assembly.

10.2 Use a minimum of two Straight Eye Nylon Slings, with a minimum working rating of 2,500 pounds per sling, to encircle barrel and curtain. Fasten ends of slings together with Screw Pin Chain Shackles with a minimum working rating of 5,000 pounds per shackle.

10.3 Lower curtain to rest in slings.

💡 NOTE: Hoisting equipment may be used at this point to lift curtain slightly, allowing barrel to be rotated manually or by awning crank to help alignment of fastening points.

10.4 Attach curtain segments to welded nuts on barrel with 5/16" x 3/8" button head screws. Do not over tighten.

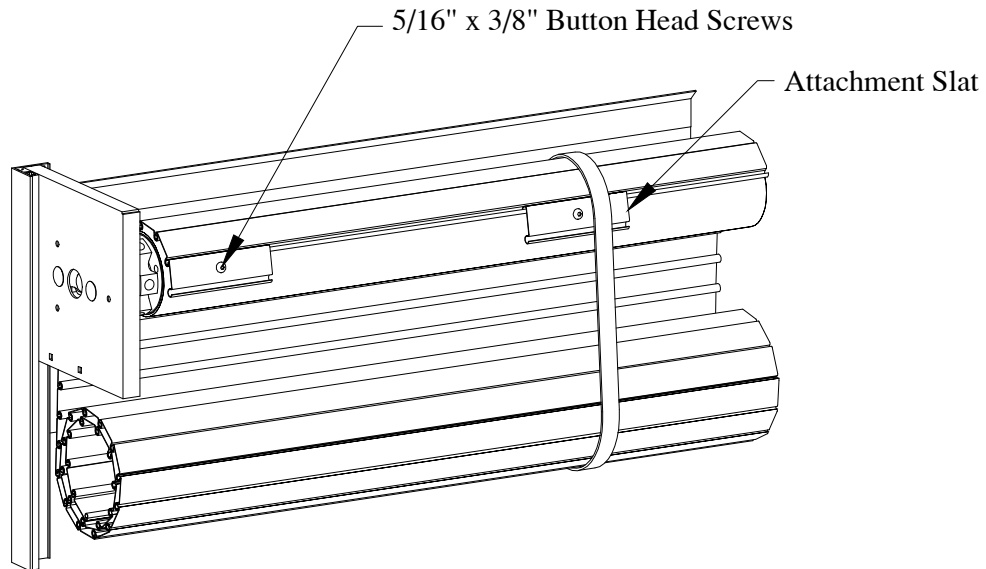

Slinging The Curtain

10.5 Transfer curtain from sling to barrel by coiling curtain around barrel until bottom bar is even with bottom edge of headplates. Tie curtain with a rope temporarily to prevent uncoiling.

⚠ WARNING!! Leave slings in place for now as a safety precaution.

11.0 GUIDE ANGLE ASSEMBLY:

11.1 Raise guide angle into position for attachment and align for fastening. Assemble fasteners to adjustable thread lockers located inside the wall angle channels.

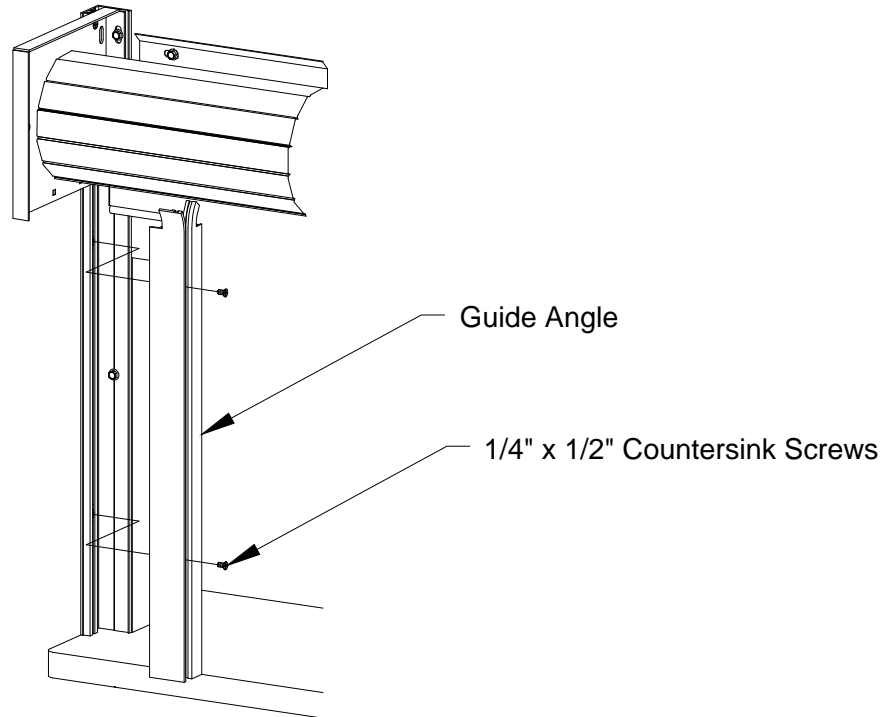

12.0 CURTAIN STOP ASSEMBLY:

12.1 Locate curtain stop and supplied fasteners. Line up holes on head plate with holes on stop having stop flush with flared guide on front guide. Bolt stop to head plate using two 1/4" x 1/2" carriage bolts on both drive side and tension side head plates.

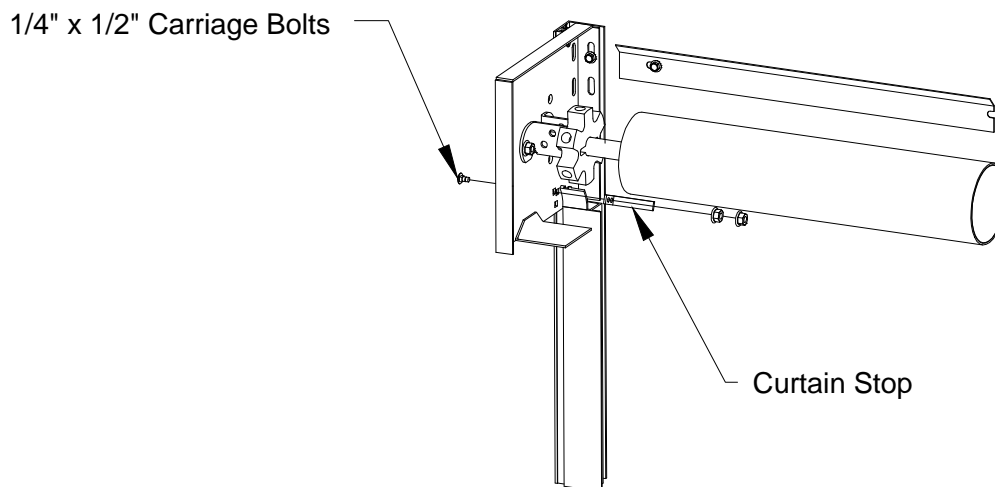

13.0 TENSIONING THE BARREL:

13.1 Lower curtain to counter.

13.2 Mark starting location on tension wheel and head plate for use as a reference while winding. Refer to number of spring turns previously recorded below, this is the number of full winds that the tension wheel will be turned. Insert one winding bar into an uppermost lug in tension wheel and pull down evenly. Insert second bar into uppermost lug, remove first bar and pull second bar down evenly.

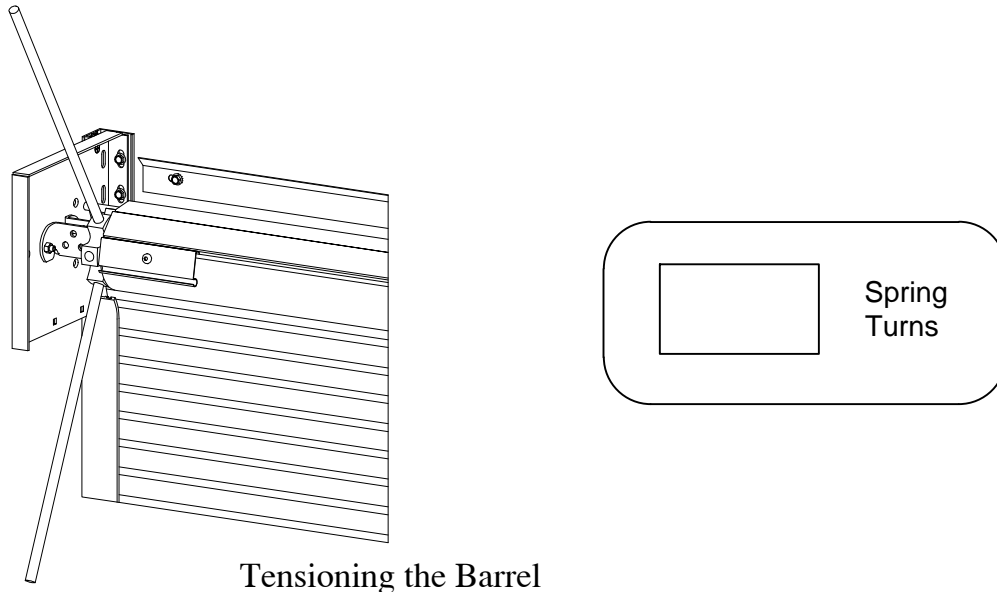

- ✔ **WARNING!!** Never exceed number of turns shown by more than one-half turn.
- ✔ **WARNING!!** Use solid steel winding bars. Be certain that winding bar diameter matches lug hole size on the tension wheel and is a minimum of 18" long. Be sure that the bar is inserted fully into the winding lug. Use of improper or undersized bars will result in component failure and cause serious personal injury or death.
- ✔ **WARNING!!** Keep your head and body out of line with the winding bars. Always maintain secure footing and balance. Firmly grasp the winding bars and be braced to resist strong forces whenever winding springs.
- ✔ **WARNING!!** From this point onward, the spring is under tension and extremely dangerous.

13.3 When proper number of turns is established, lock tensioning wheel by placing tension pin through saddle bracket and shaft, locking in place with clevis pin. Ease tension wheel back with winding bar.

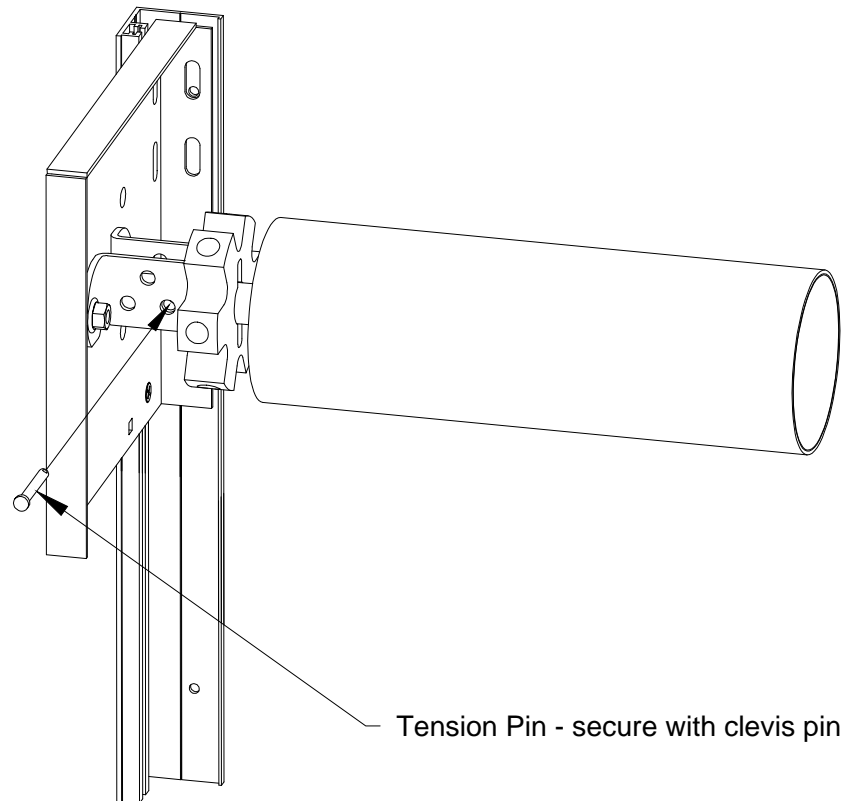

13.4 Check operation by moving shutter up and down. If tension is correct, the effort required to raise or lower shutter should be about equal and no further tensioning adjustments are necessary.

13.5 If tension needs adjustment, adjust tension in one hole increments until effort required to raise or lower the shutter is satisfactory.

14.0 HOOD INSTALLATION:

14.1 **Standard Hood:** Center hood between head plates and fasten using 1/4" x 3/4" hex head self drilling screws. Mount all fasteners near outside edge of hood.

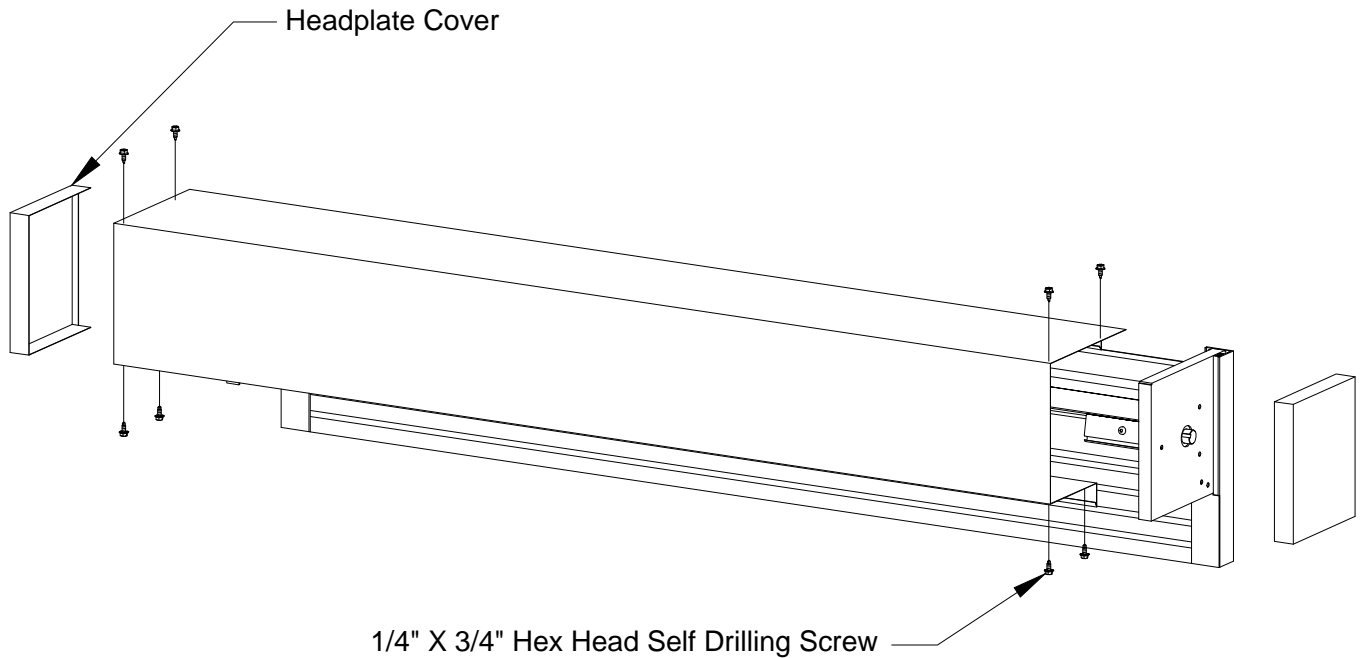

14.2 **Head Plate Covers:** Center hood between head plates. Slide head plate covers between hood and head plates. Fasten using 1/4" x 3/4" hex head self drilling screws. Mount all fasteners near outside edge of hood.

15.0 MAINTENANCE:

- 15.1 Inspect shutter for cleanliness, fit and operation every two weeks.
 - 15.2 Inspect guides, curtain and hood for wear or visible damage. Report any unusual wear or damage for immediate repair.
 - 15.3 Inspect all fasteners for tightness and for damage. Report any loose or damaged fasteners immediately for repair.
 - 15.4 Inspect guides for unusual accumulations of dirt, grease or foreign matter that would hinder normal door operation or drop procedure.
-
- ✔ **WARNING!!** Individuals operating any rolling counter shutter must do so in a prudent and safe manner. Unsafe operation or allowing personnel or property to pass through an opening when shutter is not at rest in its fully open position may result in personal injury, shutter damage or property damage. Always practice safe operating procedures and never allow property or personnel in the path of a moving shutter.
 - ✔ **WARNING!!** Wear protective gloves and eye wear when working on the shutter.
 - ✔ **WARNING!!** If in doubt of the fitness or structural integrity of jambs, a qualified engineer must inspect the existing conditions before proceeding further.
 - ✔ **WARNING!!** Guides are not intended or designed to act as structural reinforcement for existing jambs. Jamb surface must extend full height of wall angle.
 - ✔ **WARNING!!** Installation of anchoring devices into unsound building material will result in product damage, personal injury, premature wear and product failure.
 - ✔ **WARNING!!** Secure all loads to hoist equipment to prevent movement while hoisting. Do not allow personnel to ride hoist equipment. Stay off ladders and lifts until barrel and/or curtain have been hoisted to the final position of attachment. Serious personal injury will result from carelessness or lack of planning. Plan all moves carefully!
 - ✔ **WARNING!!** It is essential that you use hoisting equipment of adequate stability and rated capacity to safely lift the barrel and headplate assemblies.
 - ✔ **WARNING!!** Never exceed number of turns shown by more than one-half turn.
 - ✔ **WARNING!!** After correct tension is reached, the spring is under tension and extremely dangerous.
 - ✔ **WARNING!!** Never place fingers near any moving parts while door is in operation.
 - ✔ **WARNING!!** Adjustments or repairs to shutter should be performed only by mechanically experienced individuals who have the proper tools, instructions and a thorough understanding of the entire shutter assembly and its operation.

16.0 PAINTING: (not applicable to stainless steel, aluminum or galvanized surfaces)

16.1 Curtain slats feature finish coat polyester paint over baked on enamel primer and galvanized steel. Protective paint coats are not necessary unless desired.

16.2 Repainting the curtain: Wash surfaces thoroughly with a solution of trisodium phosphate (commonly called TSP). Buff lightly with an extra-fine-grade steel wool. Repair any rust or bare metal areas and coat with a zinc-based primer. Paint with premium-quality oil-based or latex exterior paint. Avoid use of solvents (mineral spirits can be used). Apply paint to small area of door to test for adhesion. If new paint does not chip, crack or bubble, apply to remainder of door. If in doubt about the correct paint system to use, contact a painting professional.

16.3 ASTA recommends that you closely follow paint manufacturer's recommendations for cleaning, preparing and applying paint to obtain best results.

⚠ WARNING!! Do not Paint:

- ⚠ Axles, bearings or moving parts
- ⚠ Wear surfaces on guides
- ⚠ Brush or jamb seal
- ⚠ Safety warning labels
- ⚠ Operational labels or placards

TROUBLESHOOTING

PROBLEM	PROBABLE CAUSE	REMEDY
<input checked="" type="checkbox"/> Shutter will not close all the way to the counter.	Too much spring tension.	Open shutter fully and back tension off one hole at a time until satisfactory balance is achieved (Pages 12-13).
<input checked="" type="checkbox"/> Shutter will not stay shut.		
<input checked="" type="checkbox"/> Shutter closes hard.		
<input checked="" type="checkbox"/> Shutter closes too fast.	Too little spring tension.	Open shutter fully and increase tension one hole at a time until satisfactory balance is achieved (Pages 12-13).
<input checked="" type="checkbox"/> Curtain runs to one side.	Barrel not level.	Refer to Barrel Assembly Installation. Barrel must be level (Page 8).
	Curtain not centered.	Refer to Curtain Installation (Page 10).
<input checked="" type="checkbox"/> Shutter is hard to move in either direction.	Guides too close together.	Verify that you have held the "X" dimension full height of guides (Pages 3-4).
	Guides damaged.	Check for bent or damaged guides. Slats not centered in guides and headplates (Page 11).
<input checked="" type="checkbox"/> Curtain "jumps" on way down or up.	Curtain binding on headplate or guides.	Check for bent or damaged guides.
		Check that "X" dimension has been held at headplates (Pages 3-4).
		Slats not centered in guides and headplates.
<input checked="" type="checkbox"/> Shutter difficult to raise, will not stay open at head.	Broken spring.	Contact qualified ASTA Door technician to evaluate.

To insure proper identification of this door please complete the information below.

Door Model: _____ Door Size: _____ x _____

Installed By: _____

Installation Date: _____

LIMITED WARRANTY

Commercial Rolling Steel Doors

ASTA Door Corporation warrants rolling steel doors, shutters and components to be free from defects in materials and workmanship for a period of five (5) years. Spring wire is warranted for one year. All warranty periods begin with the date of manufacture. ASTA obligations are strictly limited to repair or replacement of defective parts and components during the warranty period.

This limited warranty excludes: (1) rust caused by damages or scratching; (2) damage resulting from exposure to corrosive chemicals, corrosive fumes, condensation, water or fire; (3) damages caused by accident, improper use, negligent operation, improper installation, improper maintenance or normal wear; (4) shipping, installation or labor charges; (5) defects in paints or coatings used to finish door sections; (6) any product or component which is modified, altered, or not part of the original door, and (7) damages resulting from any circumstances beyond the direct control of ASTA

In the event of a defective component, contact the dealer the door was purchased from within fifteen (15) days from discovery of the defect. ASTA reserves the right to inspect all products alleged to be defective and to verify eligibility of this limited warranty.

THIS LIMITED WARRANTY EXCLUDES ANY LOSS OR DAMAGE NOT SPECIFICALLY UNDERTAKEN HEREIN, INCLUDING, WITHOUT LIMITATION, ANY consequential or incidental damages, such as death, injury, damages to property, or damages arising from loss of use of ANY PRODUCT OR FACILITY. All other warranties, expressed or implied, including any warranties of fitness for a PARTICULAR PURPOSE and of merchantability, are hereby expressly excluded.

This warranty is non-transferable.

