



**R O L L I N G   S T E E L   D O O R S**

4255 McEver Industrial Drive  
Acworth, Georgia 30101  
Phone: (770) 974-2600 Toll Free: (800) 423-0659  
Fax: (770) 974-1455

# ***Installation Instructions***

---

**Models: FD301-FD300**

**FD401-FD400**

**Chain Hoist**

**Fire Door**

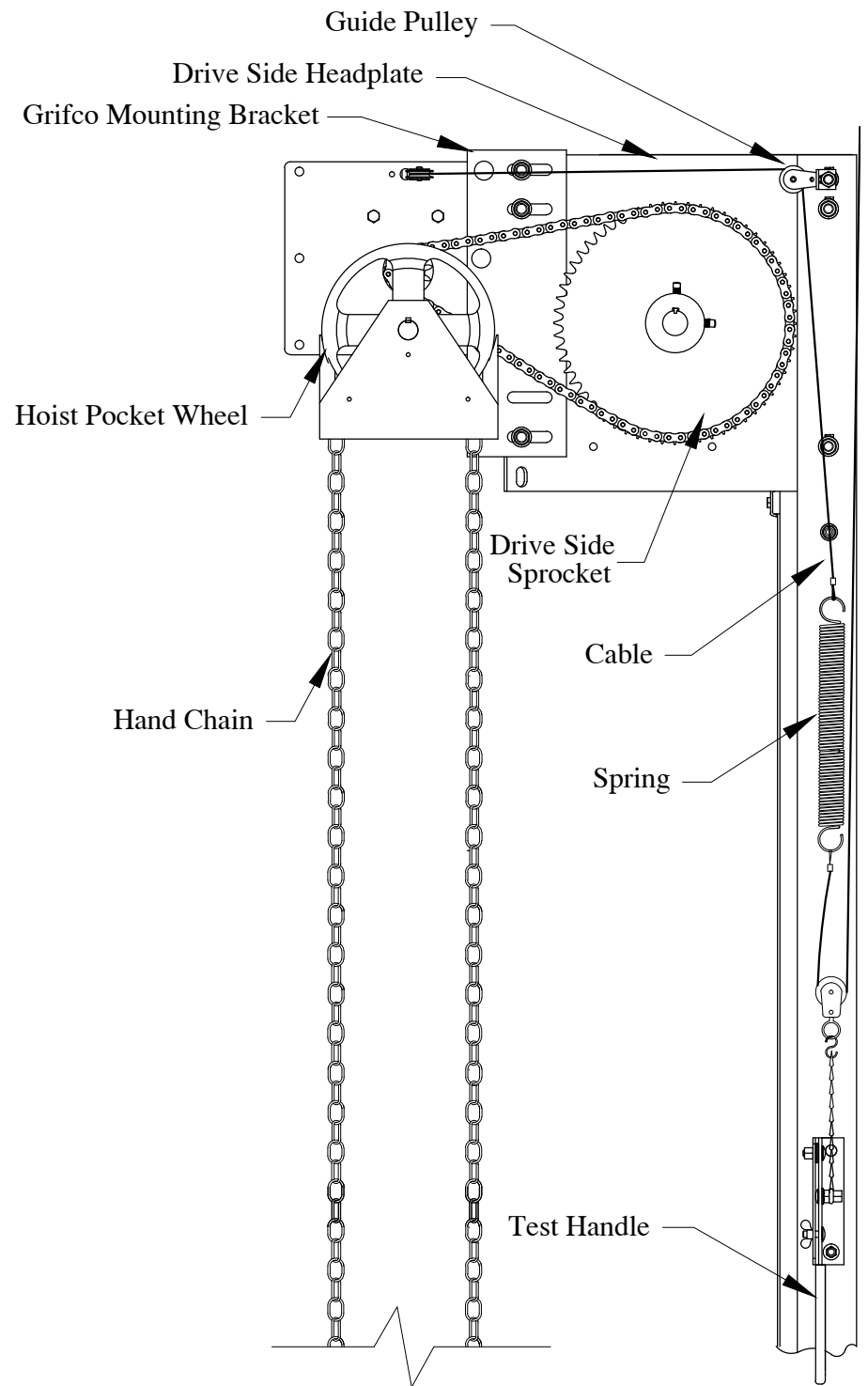
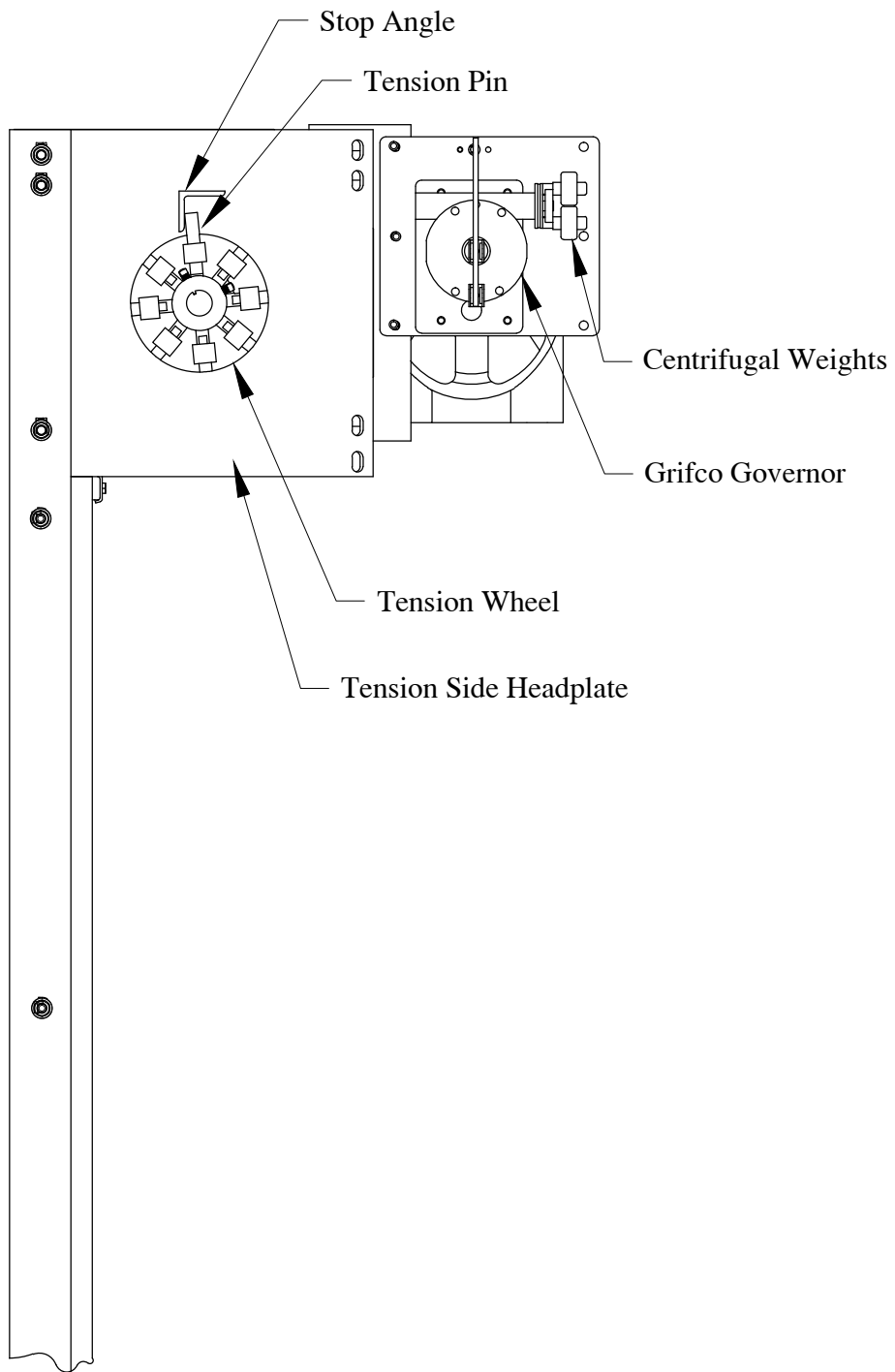

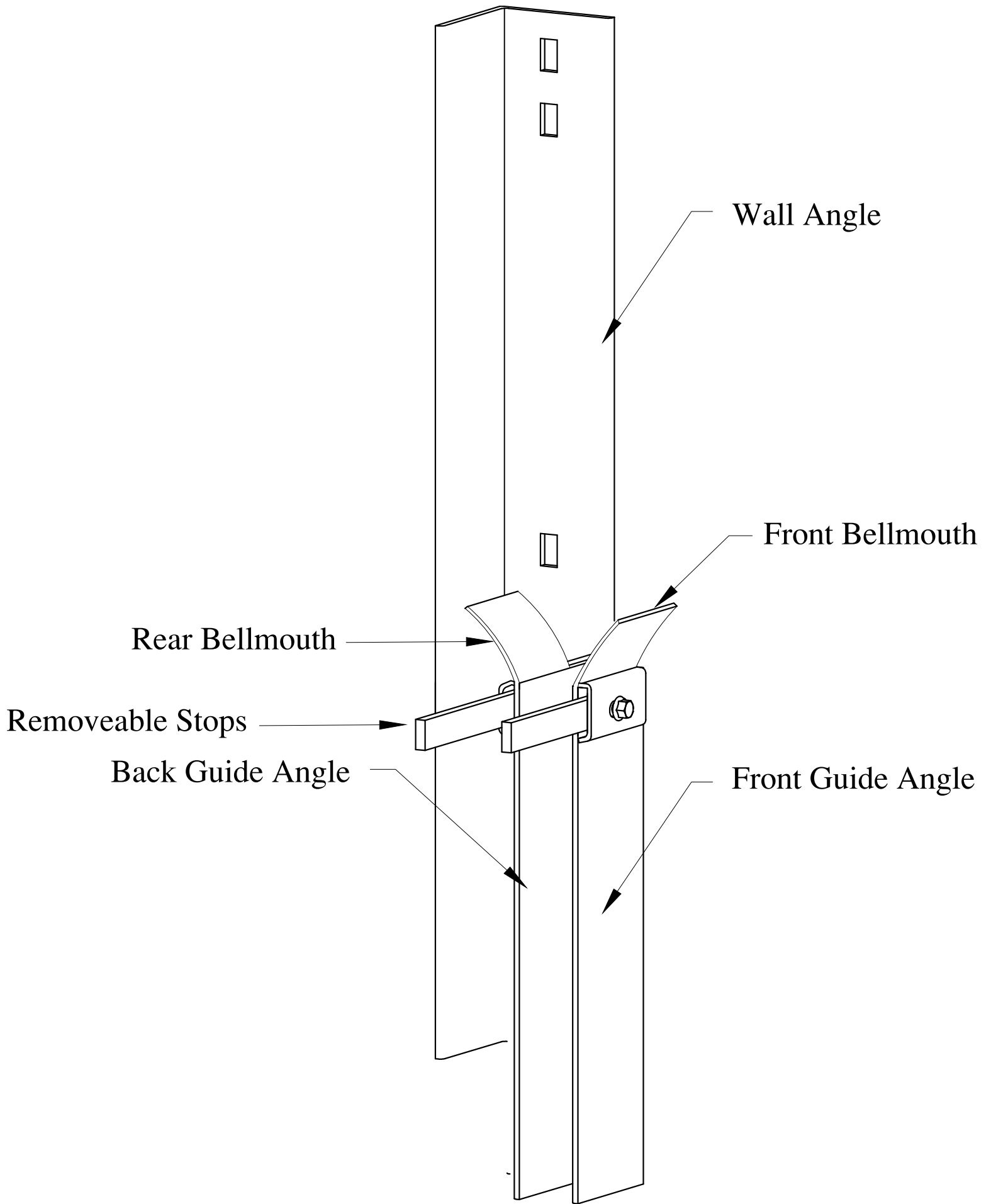

Wall Angle

Front Bellmouth

Rear Bellmouth

Removeable Stops

Back Guide Angle

Front Guide Angle

# ASTA FIRE DOOR INSTALLATION INSTRUCTIONS

## TABLE OF CONTENTS

		Guide Basics		
		Fire Door Basics		
Sections:	1.0	General	Page	1
	2.0	Shipment Inspection	Page	1
	3.0	Checking Door Requirements	Page	1
	4.0	Existing Conditions	Page	1
	5.0	Preparation	Page	1
Section:	6.0	Guide Installation	Pages	2-5
Section:	7.0	Part Identification	Pages	6-8
Section:	8.0	Barrel Installation Procedure	Page	9
Section:	9.0	Governor Chain Hoist Assembly	Pages	10-11
Section:	10.0	Curtain Installation	Page	12
Sections:	11.0	Install Curtain Stops/Bellmouths	Page	13
	12.0	Guide Installation	Page	13
Sections:	13.0	Tensioning the Barrel	Pages	14-15
Section:	14.0	Hood Installation	Page	16
Sections:	15.0	Label Installation	Page	17
	16.0	Optional Equipment Installation	Page	17
Section:	17.0	Fusible Link System	Pages	18-21
Section:	18.0	Drop Test Procedure	Page	22
Sections:	19.0	Maintenance	Page	23
	20.0	Painting	Page	23
		Trouble Shooting	Page	24

# ASTA FIRE DOOR INSTALLATION INSTRUCTIONS

These instructions will show you how to install a ASTA Rolling Steel Fire Door. They are for the mechanically experienced person who has proper tools to perform the job. They are not meant to infringe upon or supersede any State or County building codes, fire codes or safety regulations.

**Safety first.** Safety warnings are clearly marked with a **⚠️ WARNING!!** symbol. Critical information is identified by a **⚡ CRITICAL!** symbol. Tips are marked with a **💡** symbol. Observe all of the guidelines, warnings, tips and critical information given in the instructions during the installation.

**⚠️ WARNING!! Wear protective gloves and eye wear when working on the door.**

**1.0 GENERAL:** Read and familiarize yourself with this entire manual before proceeding with installation. Contact ASTA Door Corporation for technical information at 4255 McEver Industrial Drive Acworth, Georgia 30101 Toll Free:(800) 423-0659

**2.0 SHIPMENT INSPECTION:** When the shipment arrives check for freight damage and missing items. Use packing list to determine completeness of shipment. If there is damage or a shortage is detected, contact ASTA immediately.

**3.0 CHECK DOOR REQUIREMENTS:** Use shop drawing to verify the following:

- ✓ Width of opening
- ✓ Height of opening
- ✓ Headroom
- ✓ Side room
- ✓ Back room at header

**4.0 EXISTING CONDITIONS:**

- ✓ Is floor level?
- ✓ Is header level?
- ✓ Are jambs plumb?

4.1 Inspect jambs and adjacent wall construction to verify that they are suitable for anchoring door guide angle assemblies. ASTA is not responsible for the structural soundness of existing jambs and adjacent wall construction.

**⚠️ WARNING!! If in doubt of the fitness or structural integrity of jambs, a qualified engineer must inspect the existing conditions before proceeding further.**

**⚠️ WARNING!! Guides are not intended or designed to act as structural reinforcement for existing jambs.**

**⚠️ WARNING!! Installation of anchoring devices into unsound building material will result in product damage, personal injury, premature wear and product failure.**

**5.0 PREPARATION:**

5.1 Clean and sweep work area of any debris or objects that may interfere with installation or damage the curtain. Place guides and curtain on protective cardboard if possible.

5.2 Position all components on the floor in the approximate location they will be later assembled. Double check for completeness of shipment at this point.

**6.0 GUIDE INSTALLATION:** Fasteners for mounting guides are supplied by ASTA

**STEEL JAMBS**

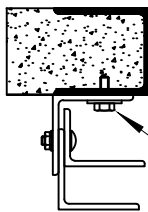
DETAIL VIEW	FASTENER SUPPLIED	DRILL SIZE	TAP SIZE
 <ul style="list-style-type: none"> <li>✓ Galvanized Washer</li> <li>✓ Hex Bolt</li> </ul>	1/2 x 1-1/4 Hex Head Thread Cutting Screws	29/34" Drill	N/A
	3/4-10 Bolt	21/32" Drill	3/4-10 UNC

**CONCRETE/ FILLED BLOCK**

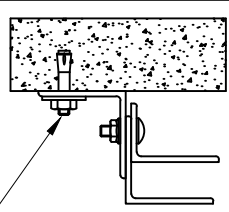
DETAIL VIEW	FASTENER SUPPLIED	DRILL SIZE	💡 NOTES
 <ul style="list-style-type: none"> <li>✓ Sleeve Type Expansion Anchor</li> <li>✓ Galvanized Washer</li> </ul>	1/2" Sleeve Anchor 3/4" Sleeve Anchor	1/2" Drill 3/4" Drill	Do not drill holes closer than 4" to the edge of any masonry.

**HOLLOW BLOCK/SOFT BRICK JAMBS**

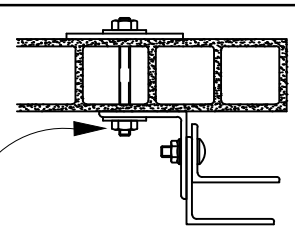
DETAIL VIEW	FASTENER SUPPLIED	DRILL SIZE	💡 NOTES
 <ul style="list-style-type: none"> <li>✓ 4 x 4 Crush Plate</li> <li>✓ Hex Nuts</li> <li>✓ Thru Bolt</li> <li>✓ Galvanized Washers</li> </ul>	1/2" Thru Bolts 3/4" Thru Bolts	1/2" Drill 3/4" Drill	-Do not drill holes closer than 4" to the edge of any masonry. -Required: 4" x 4" Crush Plates under nut on opposite side of wall.

**SHEETROCK JAMBS**

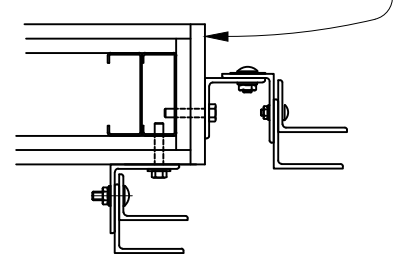
DETAIL VIEW	STEEL STUD	WOOD STUD
<p>Minimum Two Layers 5/8" Sheetrock</p> 	1-3/8" x 3-5/8" x 14 gauge minimum	2" x 4", 2" x 6", or 2" x 8"
	<ul style="list-style-type: none"> <li>✓ Drill 11/32" Pilot Hole</li> <li>✓ 3/8-16 x 2" Type T Hex Head Tapping Screw</li> </ul>	<ul style="list-style-type: none"> <li>✓ Drill 1/4" Pilot Hole</li> <li>✓ 1/2" x 3" Hex Head, Lag Screw</li> </ul>

READ AND BE SURE THAT YOU COMPLETELY UNDERSTAND ALL OF THE STEPS AND WARNINGS AS OUTLINED PRIOR TO BEGINNING INSTALLATION.

- 6.1 Guides are shipped assembled and consist of a wall angle (the longest angle), back guide angle and front guide angle (See Guide Basics).
- 6.2 The existing jamb will determine the door guide configuration you will use:  
 "E" type guides: mount to steel and sheetrock jambs.  
 "Z" type guides: mount on masonry applications.  
 "J" type guides: between-jamb mounting.

 **Accurate Guide Installation: Mark a level reference point on each jamb to insure guides are installed level with each other. Measure from the reference marks on each jamb to the floor to achieve identical elevations. Wall angles are to be set on a level floor for upward expansion. Temporarily shim one side if necessary.**

- 6.3 Disassemble front and back guide angles from wall angles.
- 6.4 Measure guide angle legs to determine proper "X" dimension. Guide leg measurement will be 3", 3-1/2" or 4" depending on size of door.
- 6.5 E & Z guides: Mark center of opening width on floor. Measure 1/2 "X" dimension (shown on shop drawing). This establishes the outside face of the mounting angle.

 **CRITICAL! The "X" Dimension is essential for proper door operation, and must be held constant from top to bottom.**

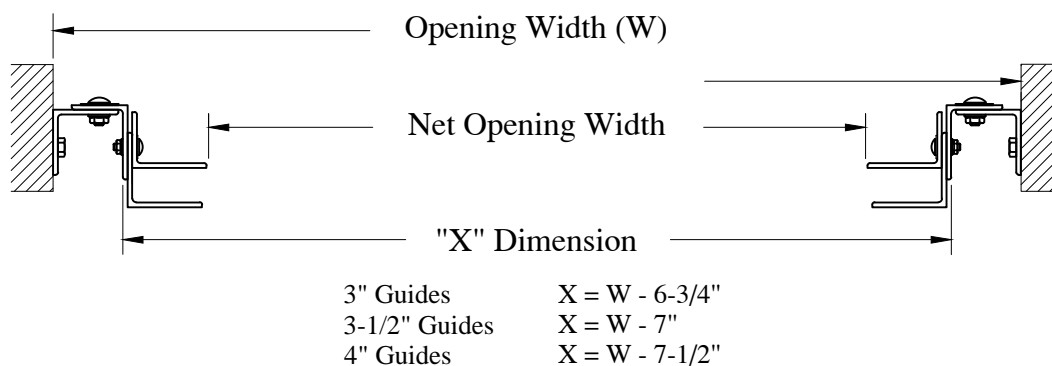
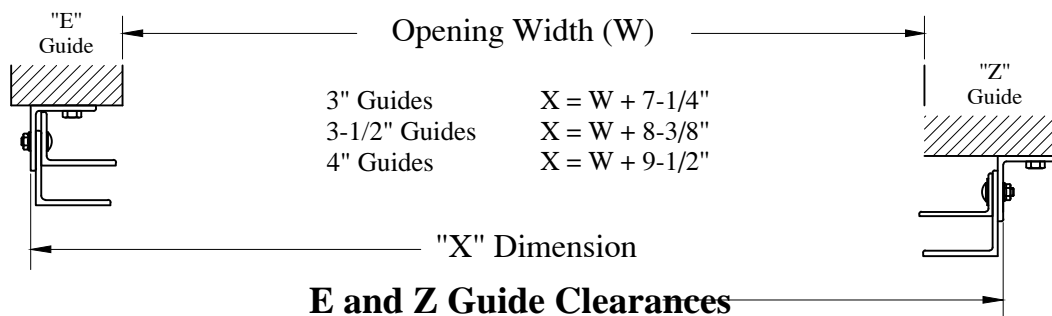

Net opening width = W - Tension side clearance - Drive side clearance

Tension Side Clearances	Drive Side Clearances
3" Guides = 6-1/2"	= 7-1/2"
3-1/2" Guides = 7"	= 8"
4" Guides = 7-1/2"	= 8-1/2"

**Standard J Guide Clearances**

6.6 Once appropriate fasteners and locations have been determined, drill holes and attach wall angle. Do not tighten fasteners until wall angle is plumb and at the desired elevation.

⚡ **CRITICAL!** Fire Door Fastener Location: This step is required by design and for Fire Door Label compliance. It must be strictly followed for proper expansion of fire door guides when exposed to heat and/or flame. All fasteners must be installed in the top of all slots.

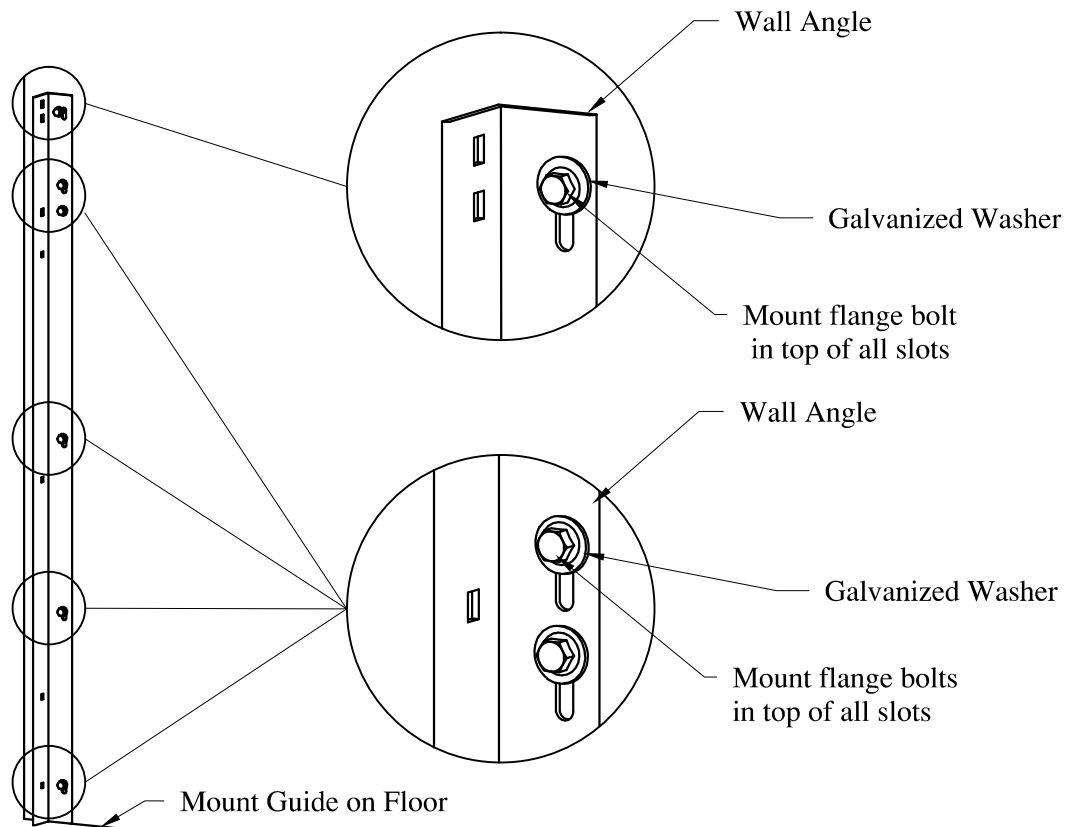

Fire Door Fastener Location

6.7 Mount opposite wall angle, paying close attention to the "X" dimension. This guide may be set by using a tape measure, provided the first guide set is installed correctly. On doors over 10' in height, use several reference points to determine an accurate "X" dimension top to bottom.

⚡ **CRITICAL!** Review all fastener locations, elevations of guides and "X" dimension before proceeding. ASTA will not warranty any door that does not have guides set plumb, level with each other, with incorrect spacing between guide faces or with fasteners set in improper locations as per installation instructions.



6.8 Weldment Procedure for Face of Wall Mounted Guides:

⚡ **CRITICAL!** Use E6010/E6011 electrodes or electrodes of equivalent strength.

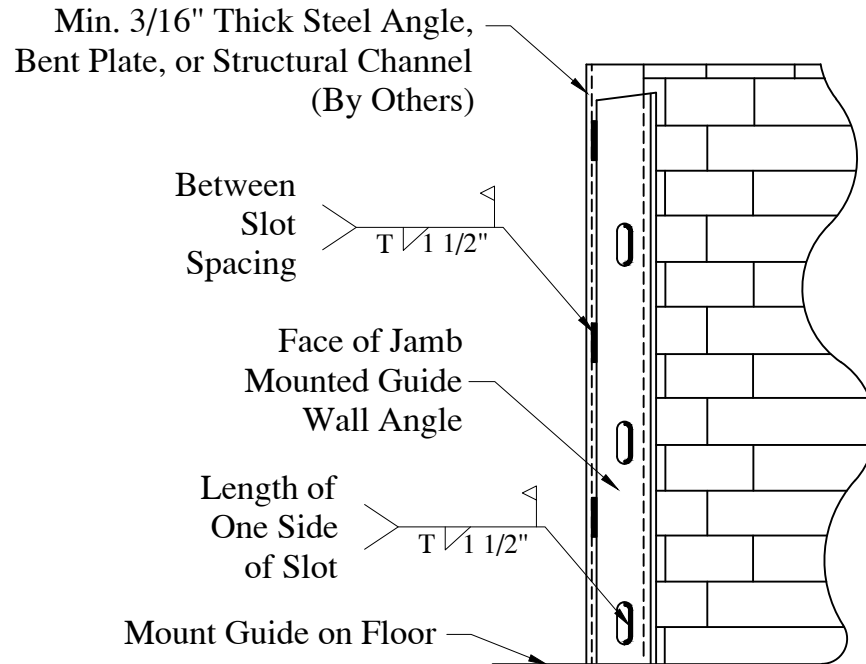

6.9 Weldment Procedure for Between Jamb Mount:

⚡ **CRITICAL!** Use E6010/E6011 electrodes or electrodes of equivalent strength.

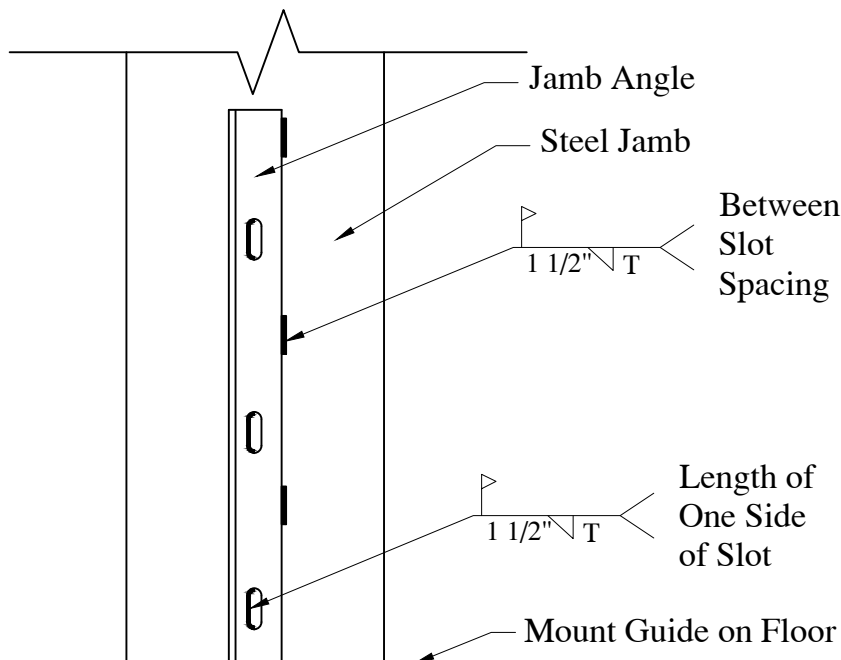

**7.0 PART IDENTIFICATION:**

7.1 Identify drive side and tension side head plate. Drive side head plate must match drive side shown in shop drawing.

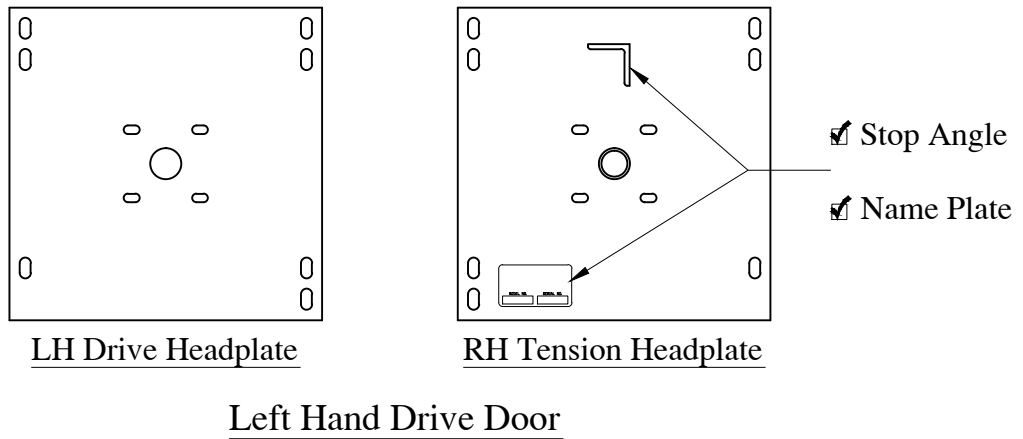
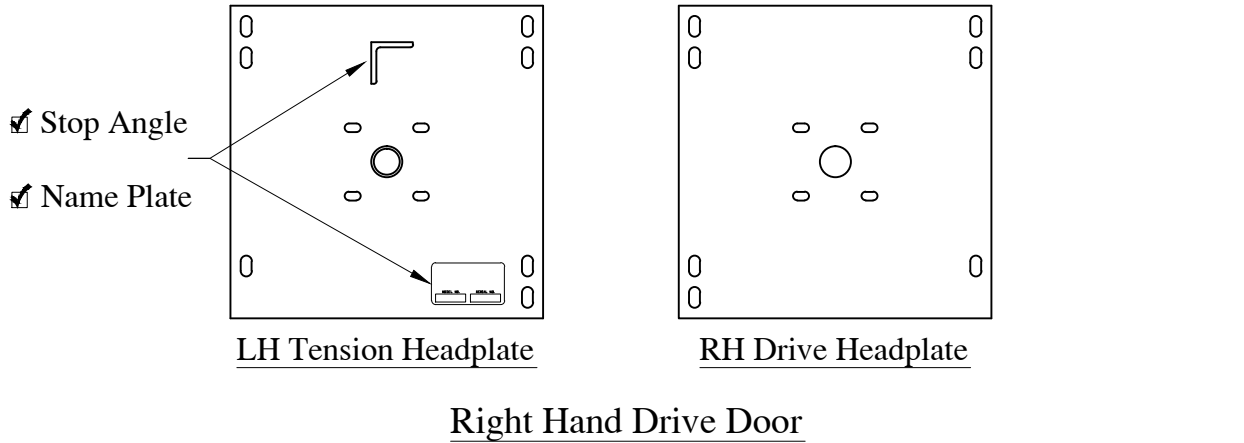

7.2 Barrel ends are identified by drive side and tension side.

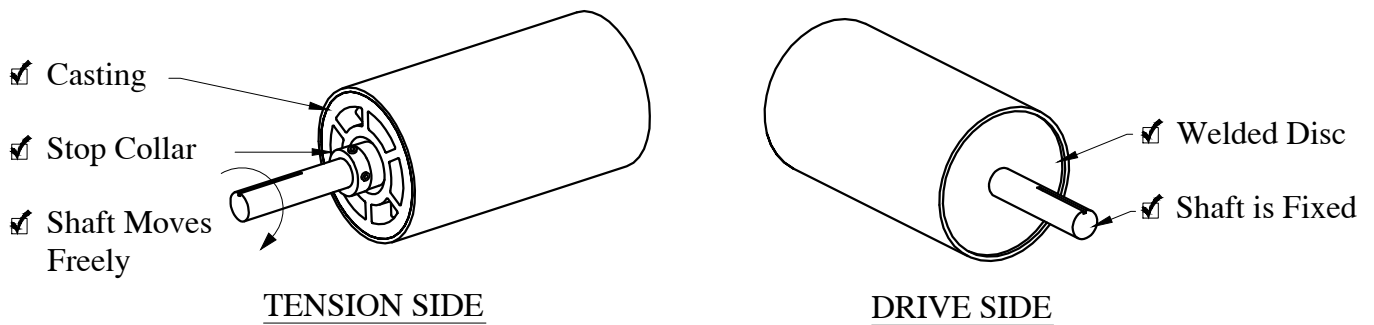

### 7.3 Tension Side Assembly.



## Steel Ring Spacer Installation

- \* Steel ring spacer will be provided and used for barrel assemblies with 1" tension shafts only.
- \* 1-1/4" tension shafts do not require steel ring spacer.

- ✓ Slide PVC spacer collar onto shaft.
- ✓ Slide steel ring spacer onto shaft.
- ✓ Slide headplate onto shaft.
- ✓ Slide tension wheel onto shaft until flush with end of shaft.
- ✓ Insert key stock and tighten set screws on tension wheel.
- ✓ Slide headplate out so that it rests against tension wheel.
- ✓ Slide steel ring spacer out and into headplate bore, this will center shaft in headplate.

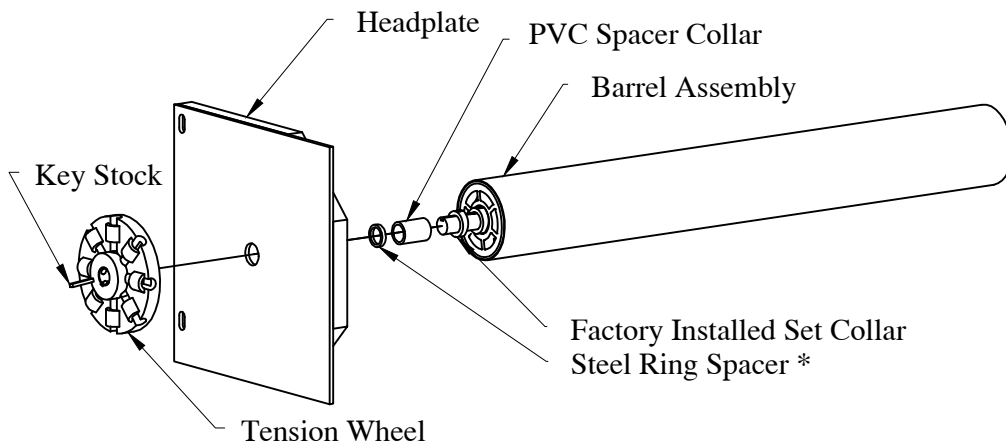

- ✓ Slide PVC spacer collar & stop collar to inside headplate and tighten set screws to hold in place.

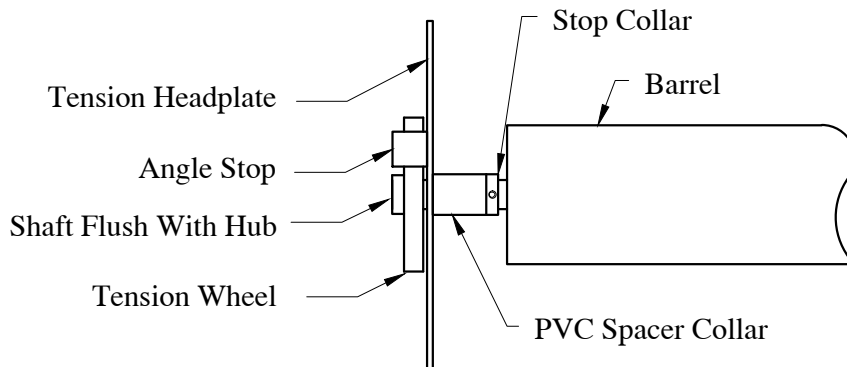

7.4 Drive Side Assembly: Mount the flanged pillow block bearing to the center of the slot pattern on the inside face of the drive side head plate with the four 3/8" bolts, lock washers and nuts. Be sure to mount bearing with the grease fitting facing down (\*). Slide the head plate assembly onto the drive shaft, (remove burrs as necessary with a file and/or emery cloth). It is important that this assembly slide on easily. Do not tighten the bearing set screws at this time.

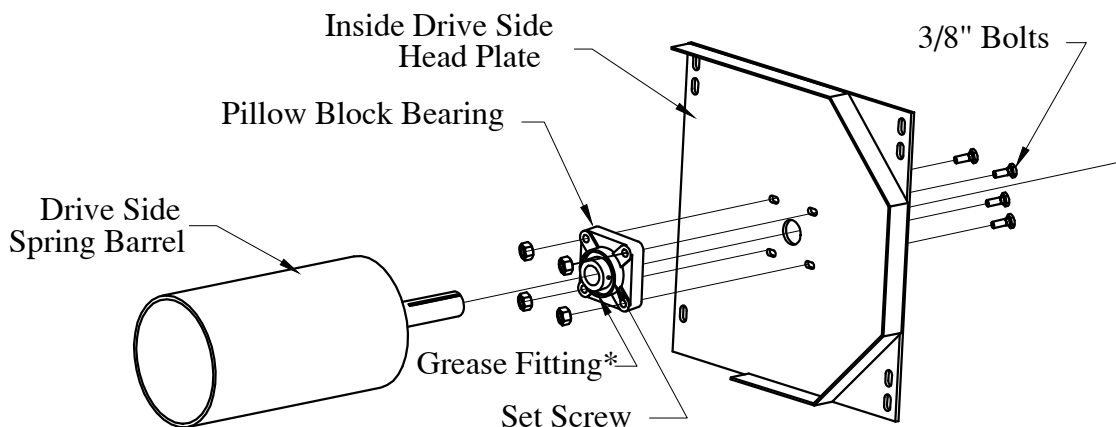

7.5 Drive Sprocket Assembly: Slide the sprocket onto the shaft until flush with the end of the shaft. Insert key, and lightly tighten set screws. Final adjustments are to be made in the next step when installing drive chain to governor.

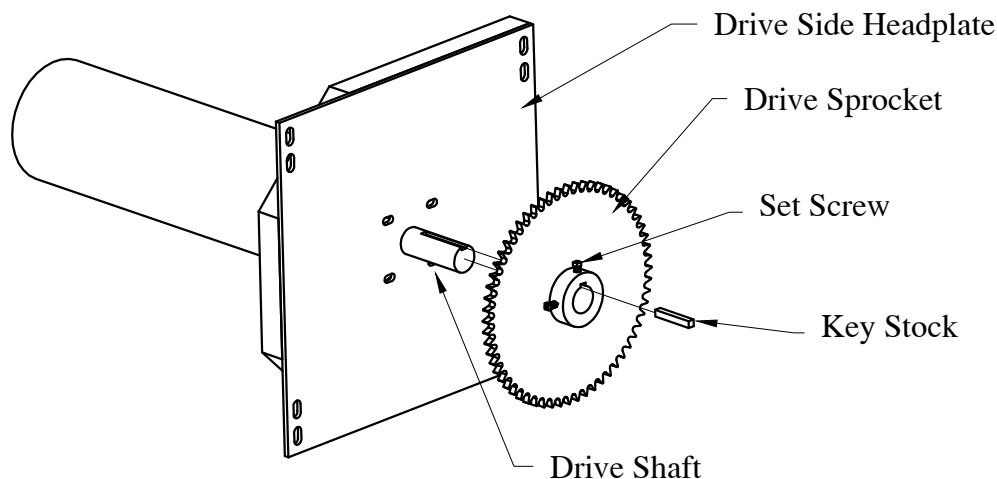

**REMINDER:** Before installing curtain, note the number of preload turns written on the barrel and record that number in the space provided on page 14 section 13.1. After curtain installation, spring barrel will be covered by curtain and preload turn number will no longer be visible.

## 8.0 BARREL INSTALLATION PROCEDURE:

- ✔ **WARNING!!** Secure all loads to hoist equipment to prevent movement while hoisting. Do not allow personnel to ride hoist equipment. Stay off ladders and lifts until barrel and/or curtain have been hoisted to the final position of attachment. Serious personal injury will result from carelessness or lack of planning. Plan all moves carefully!
- ✔ **WARNING!!** It is essential that you use hoisting equipment of adequate stability and rated capacity to safely lift the barrel and head plate assemblies.

8.1 Carefully raise the barrel assembly into position to bolt headplates to wall angles. Head plates mount to the inside face of wall angles with carriage bolts. Wall angle may be punched for two or three bolts. Use all bolts provided. Bolts are inserted from inside of headplate facing out. Fasten nuts to bolts on outside of wall angle.

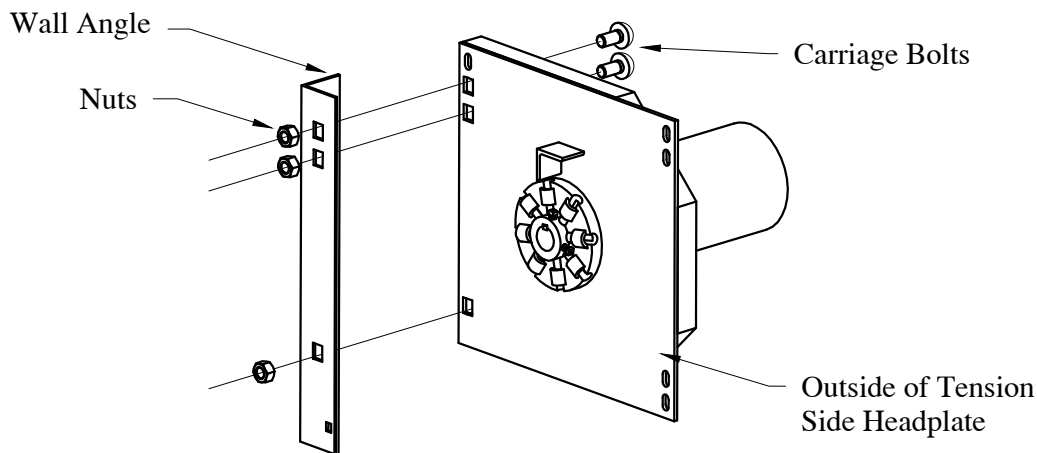

Tension Side Assembly

⚡ **CRITICAL!** Do not proceed unless barrel is level.

8.2 Once barrel is level, tighten all fasteners securely.

8.3 Check barrel rotation. Barrel should turn freely without binding.

💡 **At this time double check hood length. Hood length measurement should be approximately 1/2" shorter than the distance between headplates to allow for proper expansion.**

💡 **Measure distance between drive side and tension side headplates at the wall and at the front of the headplates. Square the headplates by obtaining the same dimension at wall and at front of headplate. When headplates are square tighten bearing set screws.**

## 9.0 GOVERNOR CHAIN HOIST ASSEMBLY:

- 9.1 Two set screws must be installed in both the 12 tooth gear and pocket wheel. Install keys under set screws.
- 9.2 Install mounting plate to chain hoist/governor with three 3/8" carriage bolts and nuts.

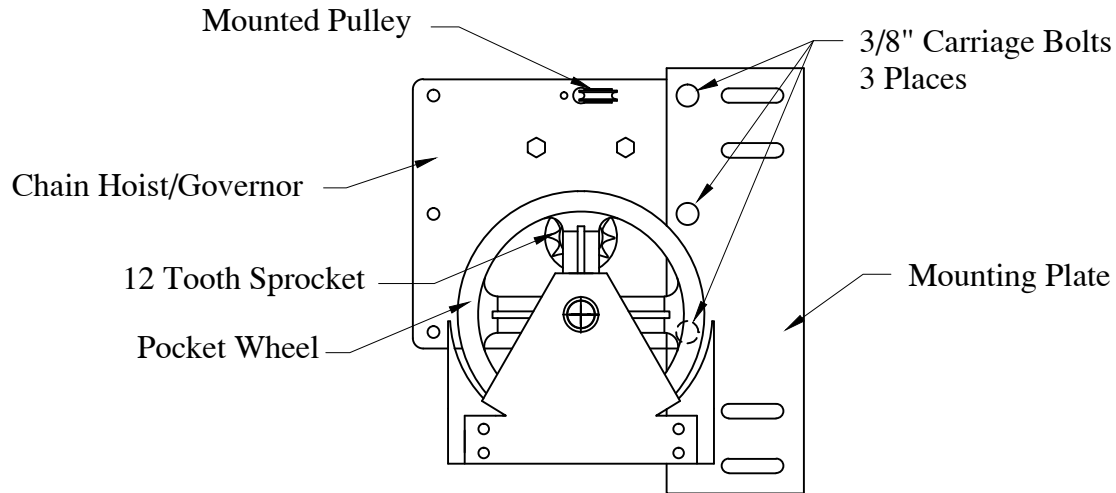

Hoist Governor Mounting Plate / Right Hand Drive Shown

- 9.3 Bolt chain hoist/governor assembly loosely to head plate using two 1/2" carriage bolts and nuts. Insert bolts from the inside, with nuts facing out.

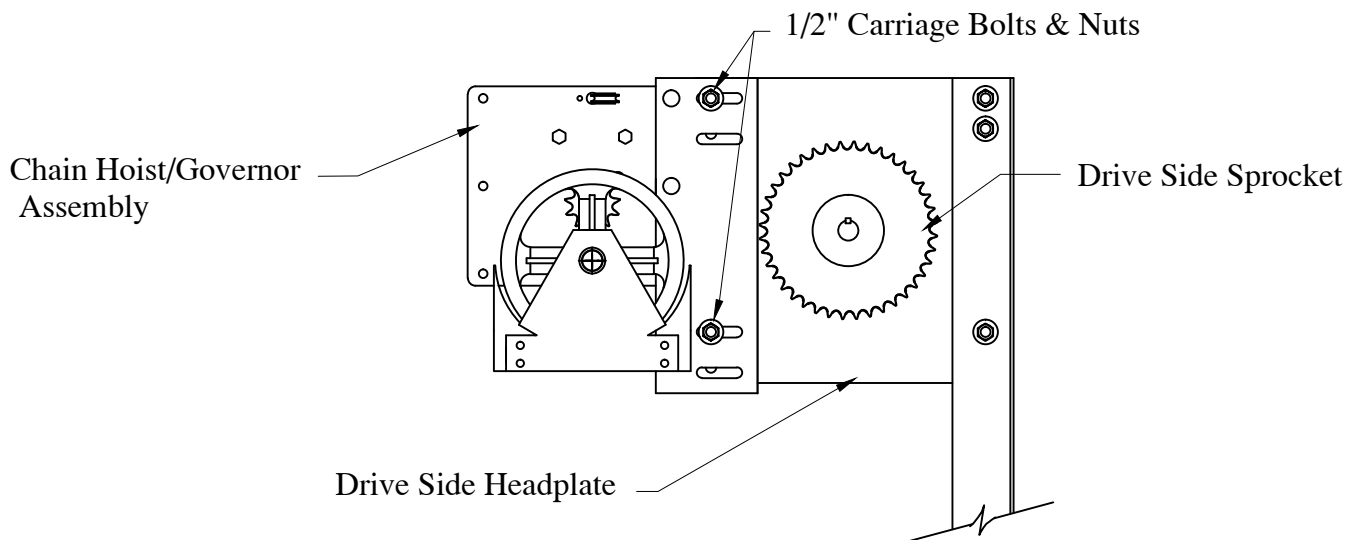

Chain Hoist/Governor & Headplate Assembly

- 9.4 Align sprockets with a straight edge. Tighten set screws checking to see that key stock is in place. Install #50 roller chain allowing 1/8"- 1/2" slack in the chain overall. This is necessary for the brake lever and chain hoist to disengage during drop testing. Install hand chain making sure there are no twists in the chain.

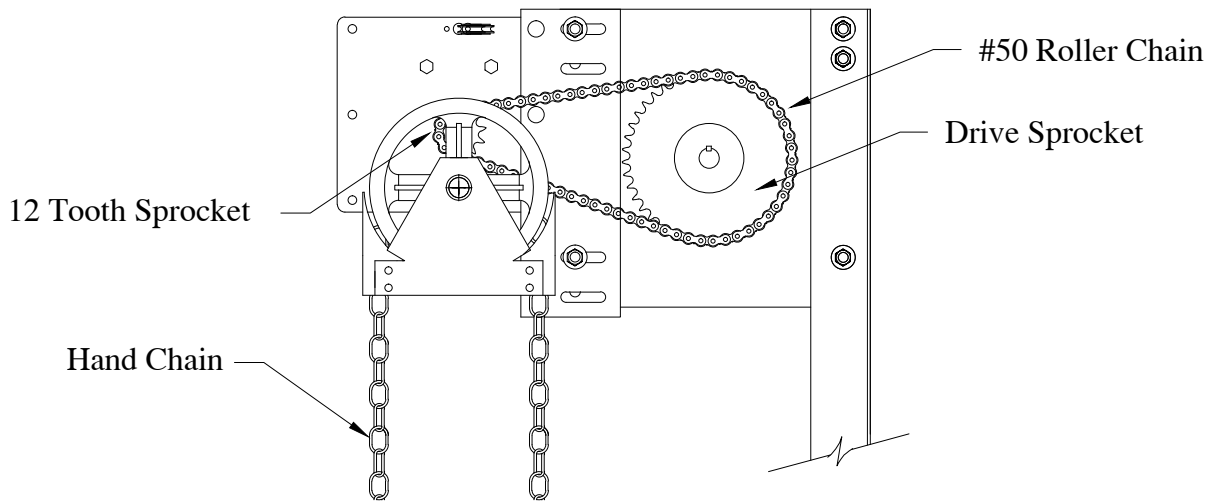

Chain Hoist/Governor Assembly with chain

- 9.5 Push brake lever forward towards chain hoist while pulling hand chain until you feel the brake lever seat fully. Secure this lever with wire or non-stretch rope in the fully engaged, or forward position.

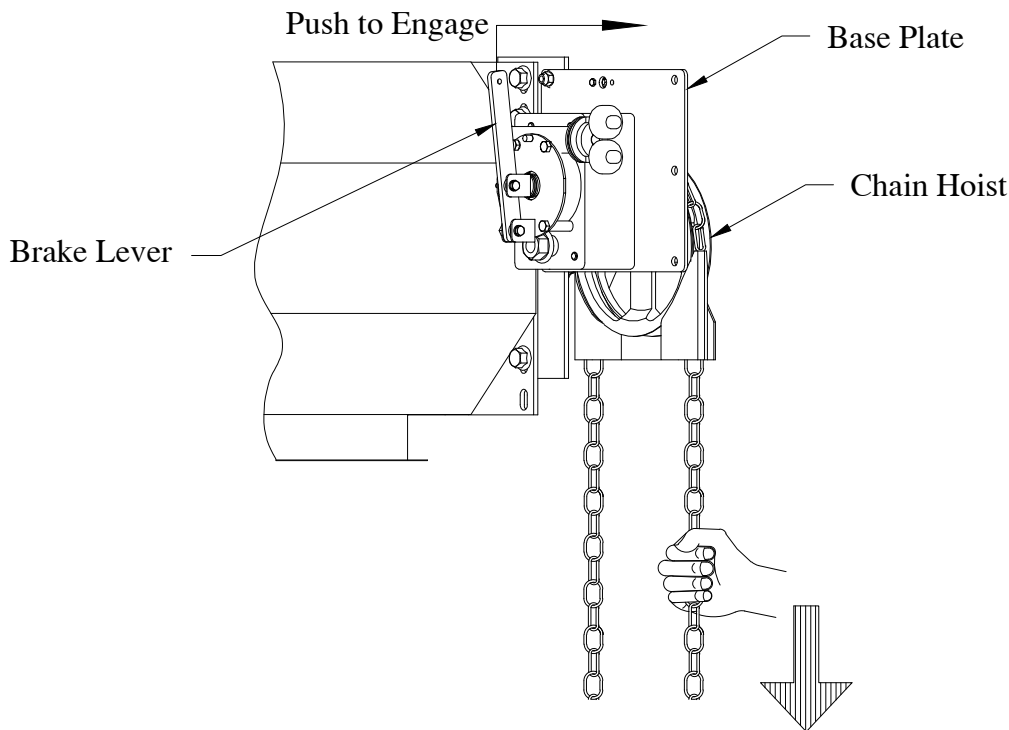

- 9.6 Evaluate wall conditions and door size. You may elect to brace the hoist/governor plate to the wall with angle iron. Use existing holes in the base plate if possible.

## 10.0 CURTAIN INSTALLATION:

 **REMINDER:** Before installing curtain, note the number of preload turns written on the barrel and record that number in the space provided on page 14 section 13.1. After curtain installation, spring barrel will be covered by curtain and preload turn number written on barrel will no longer be visible.

10.1 Secure curtain to hoist and lift into place directly under barrel assembly.

10.2 Use a minimum of two Straight Eye Nylon Slings, with a minimum working rating of 5,000 pounds per sling, to encircle barrel and curtain. Fasten ends of slings together with Screw Pin Chain Shackles with a minimum working rating of 10,000 pounds per shackle.

10.3 Lower curtain to rest in slings.

 **CRITICAL!** If barrel has rings, slings must pass over top of rings.

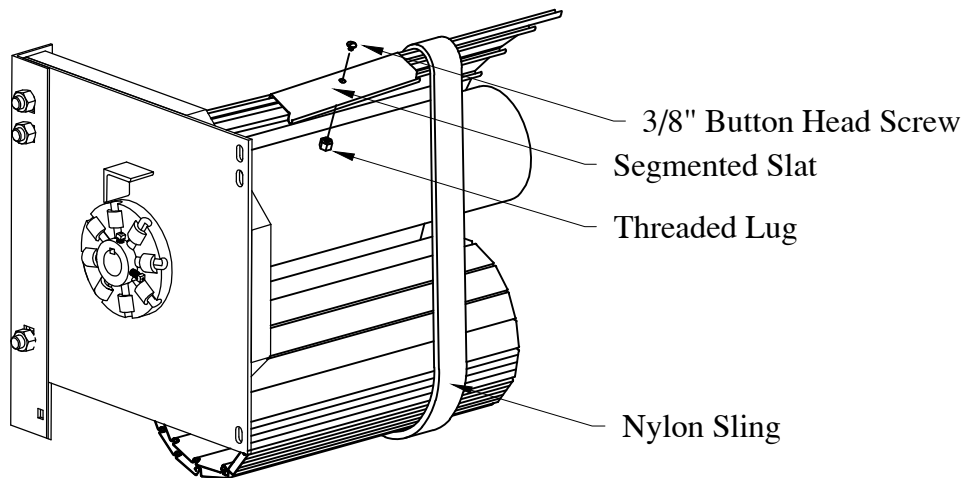

Slinging The Curtain

 **NOTE:** Hoisting equipment may be used at this point to lift curtain slightly, allowing barrel to be rotated with chain hoist to help alignment of fastening points.

10.4 Clamp two curtain attachment segments directly to slings with vise grips. Turn chain hoist to pull curtain up and over the top of barrel.

10.5 Attach curtain segments to lugs (6" and larger barrels) or to welded nuts on rings (4" barrels) with 3/8" x 1/2" button head screws. Do not over tighten.

10.6 Transfer curtain from sling to barrel by turning chain hoist. Center curtain as it is being wound onto barrel. Use winding bars at each curtain edge to adjust slats to center. Wind curtain until bottom bar angle is even with bottom of head plate. Secure chain hoist to hold curtain from uncoiling.

 **WARNING!!** Leave slings in place for now as a safety precaution.



## 11.0 INSTALL CURTAIN STOPS:

- 11.1 Install rear stops to back guides, left and right. Do not install the front stops until after both guides are erected and curtain is in proper position.

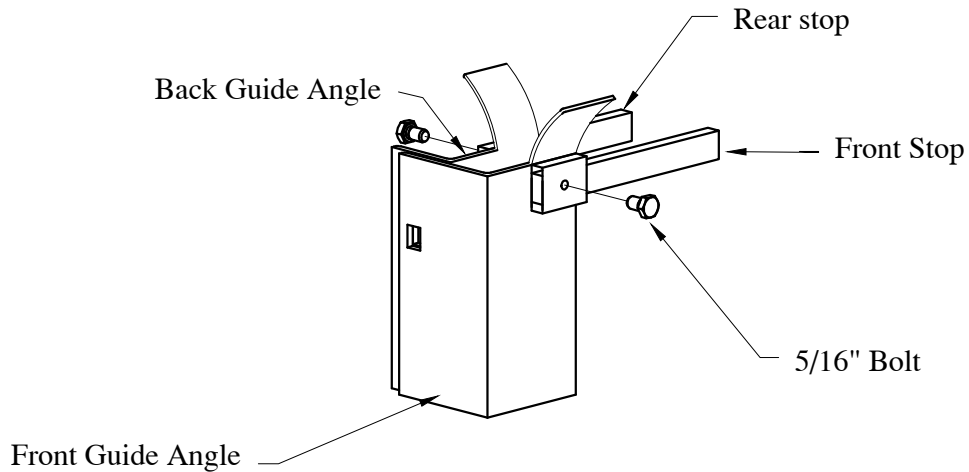

## 12.0 GUIDE INSTALLATION:

- 12.1 Raise one guide assembly (front & back angles) into position for final attachment and align for bolting. Assemble using supplied fasteners. Bolts may be inserted from either side, depending upon preference.
- 12.2 As you tighten guide bolts, spread the guides apart using winding bars or hammer claws for maximum throat width. Start at the top and work your way down.
- 12.3 Lower curtain into guide throat until bottom bar angle is 3" - 5" below the rear stops. Place a vise grip below the bottom bar angle on each guide to block further downward travel of the curtain.
- 12.4 Install front stops now.

### 13.0 TENSIONING THE BARREL:

13.1 Mark starting location of the tensioning wheel on head plate with chalk or marker for use as a reference while winding. At this time, refer to the specified preload number found recorded in the space provided inside figure below. Insert one winding bar into an uppermost lug in the tensioning wheel and pull down evenly. Lock the tension wheel by inserting the second winding bar or tension pin into the uppermost available lug.

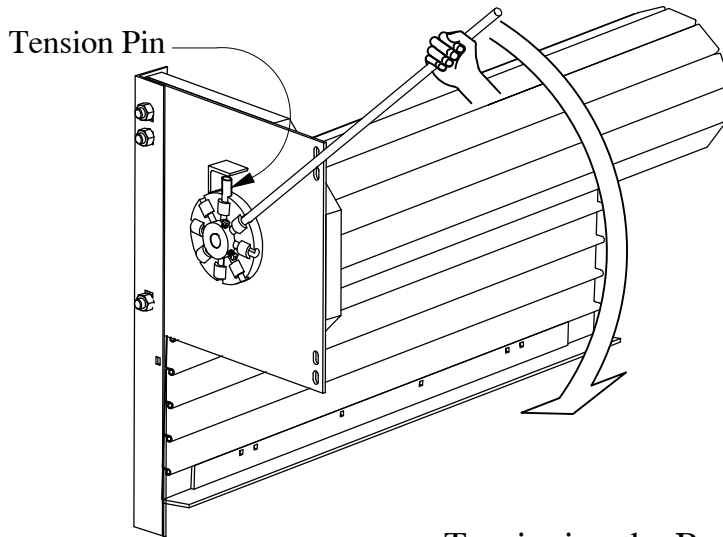

Preload Amount	
<input type="text"/>	Turns

Tensioning the Barrel

- ✓ **WARNING!! Never exceed number of turns shown by more than one-half turn.**
- ✓ **WARNING!! Use solid steel winding bars. Be certain that winding bar diameter matches lug hole size on the tension wheel and is at least 18" long. Be sure that the bar is inserted fully into the winding lug. Use of improper or undersized bars will result in component failure and cause serious personal injury or death.**
- ✓ **WARNING!! Keep your head and body out of line with the winding bars. Always maintain a secure footing and balance. Firmly grasp the winding bars and be braced to resist strong forces whenever winding springs.**
- ✓ **WARNING!! From this point onward, the spring is under tension and extremely dangerous.**

13.2 When proper preload is established, lock tensioning wheel by placing the short tension pin into appropriate casting lug, then easing wheel back with winding bar to let the tension pin rest on the angle iron stop.

13.3 Double check that Bellmouths have been securely installed. It is now safe to remove slings, vise grips and release hand chain for test operation. Do not release brake lever on governor.

13.4 Raise curtain to full open with bottom bar angle touching bellmouths. Once again, install vise grips on guides 3" - 5" below bellmouths.

- 13.5 Release hoist/governor brake lever arm, which was secured earlier. This releases the holding brake and chain hoist and allows governor to control decent. Curtain should start downward out of the head when lever is released.
- 13.6 If curtain does not start down from the head refer back to tensioning instructions (section 13.0). Remove tension by reversing tensioning procedure in one lug increments until curtain reliably moves downward every time you release brake lever. Test this function several times.

 **Door should always rest against the bellmouths when fully open with no downward travel.**

⚡ **CRITICAL!** This is a Fire Door. It must always drop in the event of a fire. Do not over tension for any reason. This door must descend when brake lever arm is released. Over tensioning will cause the curtain to drop too slow or stop completely. Under tensioning will allow it to drop too fast. Make sure tension pin is locking tension wheel to angle iron stop at all times.

13.7 Securely engage brake lever arm. Run door slowly all the way down to floor with chain hoist. There may be points of travel where door will not stop and hold. This is a normal trade-off between holding the door and chain hoist gear reduction and typically occurs mid-travel.

⚡ **CRITICAL!** If chain hoist slips or jumps while raising door from full closed position check chain and sprockets for slippage and then if nessesary, adjust holding brake adjustment:

**Holding Brake Adjustment:** Lower curtain to floor with hand chain. Loosen set screw found on the holding brake adjustment nut. Turn adjustment nut 1/2 turn clockwise. Tighten set screw. Refer back to section 13.7 to test door again.

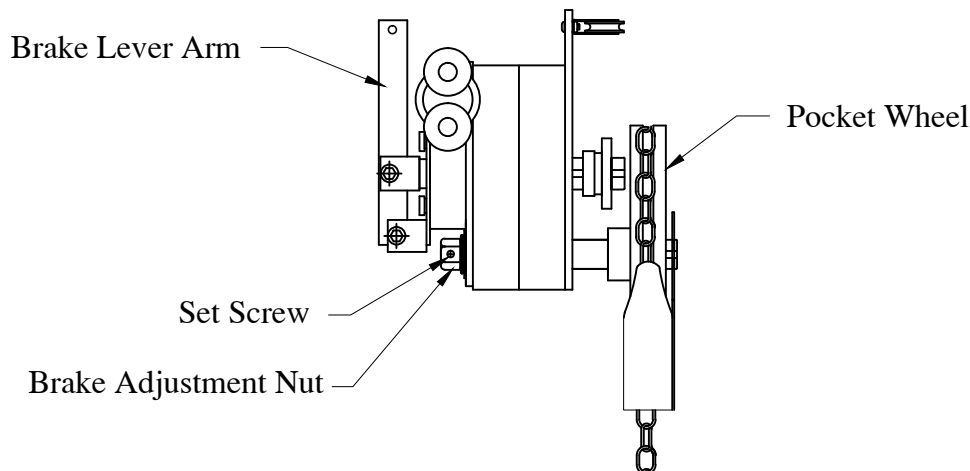

Holding Brake Adjustment

## 14.0 HOOD INSTALLATION:

14.1 Close door to floor with chain hoist.

14.2 ONE PIECE HOOD: Center hood between the headplates and fasten using 1/4" x 3/4" long hex head self drilling screws. Mount all fasteners near the outside edge of the expansion slots to allow for proper expansion.

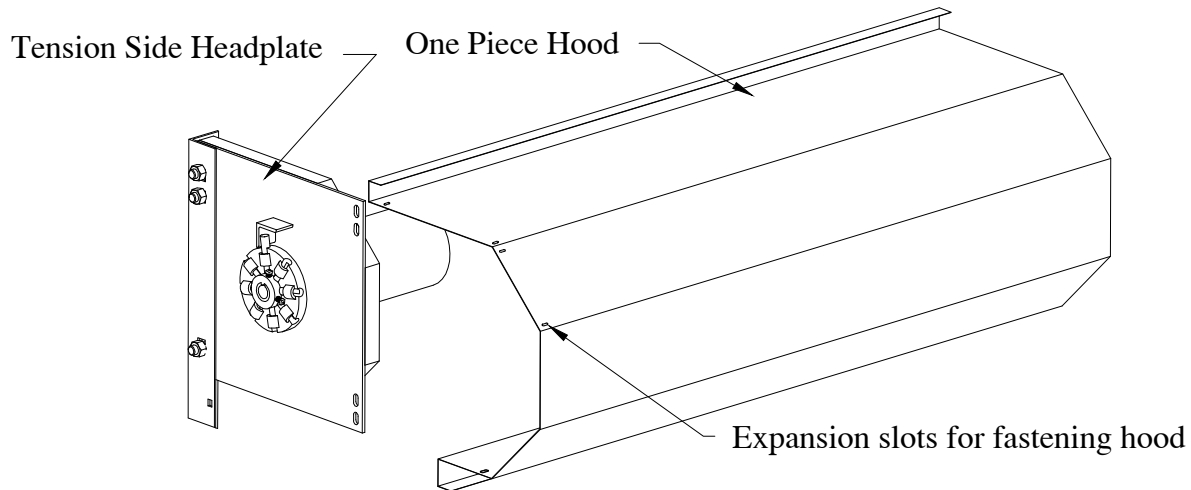

14.3 CENTER HOOD SUPPORT: Doors with two piece hoods are designed to be butt joined at the center of the door on a center hood support. Snap a chalk line from the top of each headplate. Find and mark the center on the chalked line between the headplates. Install center hood support with the top flush to the chalked line and centered in the opening. Attach center hood support with fasteners suitable for wall construction (ASTA does not provide these fasteners).

14.4 ATTACHING MULTIPLE HOOD: Center hoods between headlates and butt-join on center hood support. Fasten with 1/4" x 3/4" hex head self drilling screws. Mount all fasteners near the outside edge of the expansion slots to allow for proper expansion.

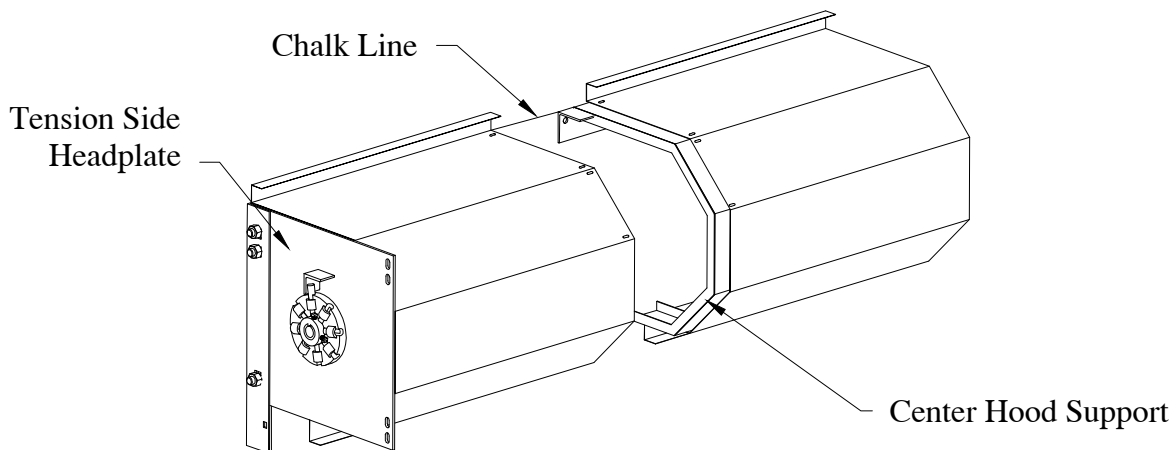

## 15.0 LABEL INSTALLATION:

15.1 Place all "Warning" and "Caution" labels as instructed on labels. Be sure they are visible at all times.

## 16.0 OPTIONAL EQUIPMENT INSTALLATION:

### Optional Slide Lock:

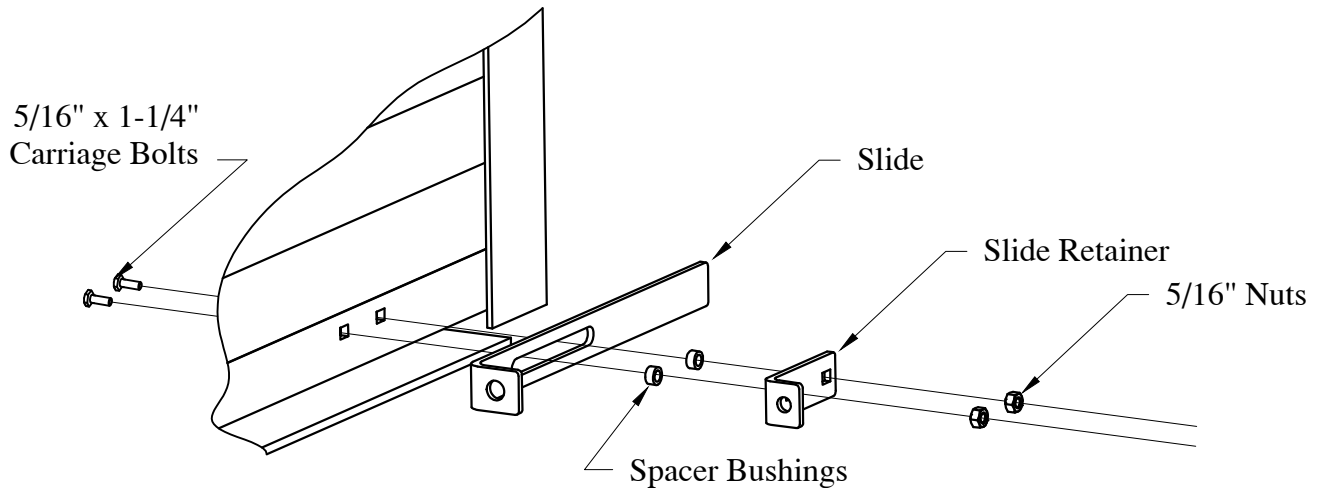

Slide Lock Installation

Install slide lock with carriage bolts supplied. Bolts are to be inserted through the bottom bar angles from the outside of the curtain. Slide locks are designed to function on the coil side of the curtain.

### Optional Header Brush Seal:

Brush seal is supplied in one to three lengths sufficient to span the distance between headplates.

If more than one piece, assemble brush seal and retainer in unequal lengths so that the brush portion helps connect the aluminum retainer.

Place curtain in the fully closed position before installation of brush seal. Install brush seal so that it maintains approximately 1/4" contact with the curtain on all surfaces. Due to the large variety of jamb types, ASTA does not supply fasteners for brush seal.

## 17.0 FUSIBLE LINKS SYSTEM:

17.1 S-hooks, fusible link, 3 foot length of cable, guide pulley and spring are factory installed to the brake lever arm on the Grifco governor. Attach guide pulley to drive side wall angle, loosen top headplate nut and attach using slot provided on pulley bracket.

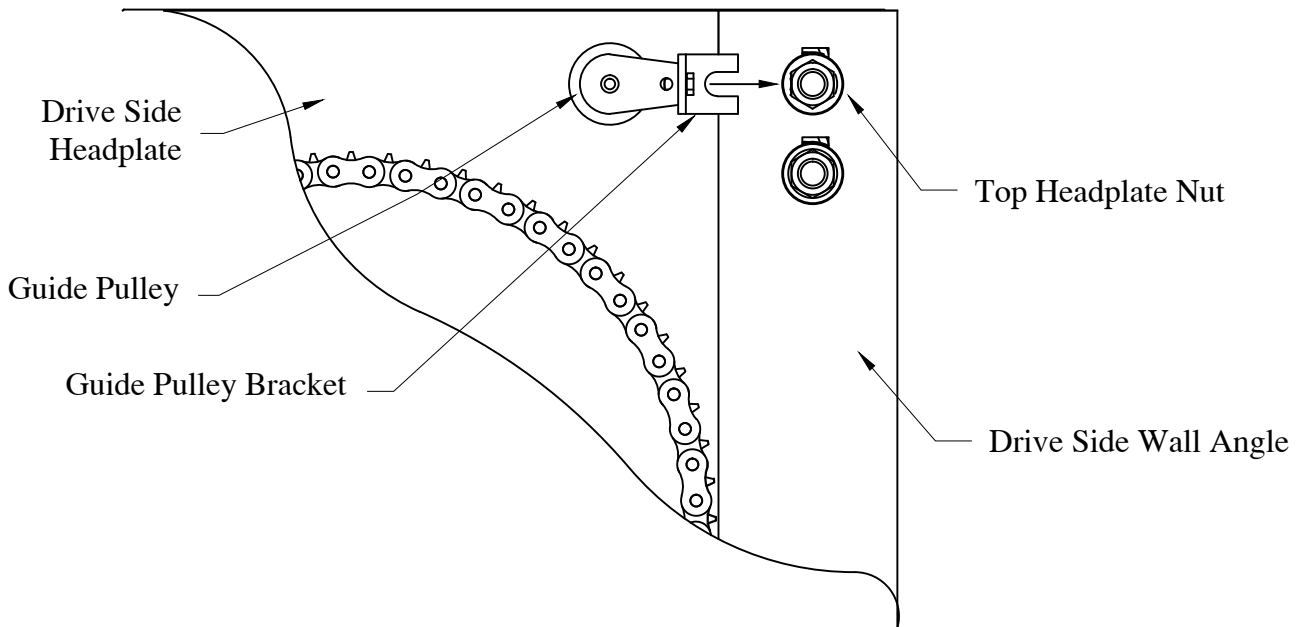

17.2 Mount test handle to the wall angle approximately five feet from floor using an existing guide bolt. Use the bottom hole in the test handle base angle for mounting to the guide. Chain and pulley are factory installed to the center bolt in test handle.

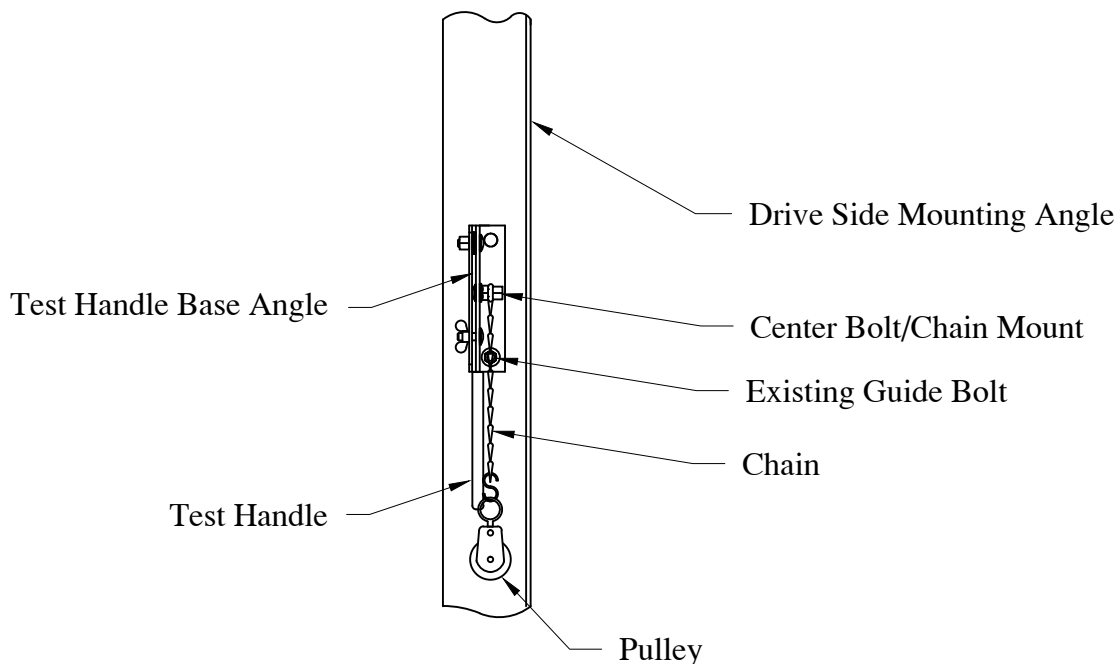

17.3 FUSIBLE LINKS: One fusible link is required within 12" of the ceiling opposite the coil side of the door. Another fusible link is a "link" in the cable located within 12" of the ceiling on the coil side of the door. S-hooks are provided to connect fusible links to loops in cable ends and are to be secured with ferrules. Route cable and fusible links in such a way that the release of the cable or the separation of any fusible link will release the brake lever arm on the Grifco governor chain hoist unit.

⚡ **CRITICAL!** Refer to NFPA-80 for placement guidelines and check local code requirements before completion.

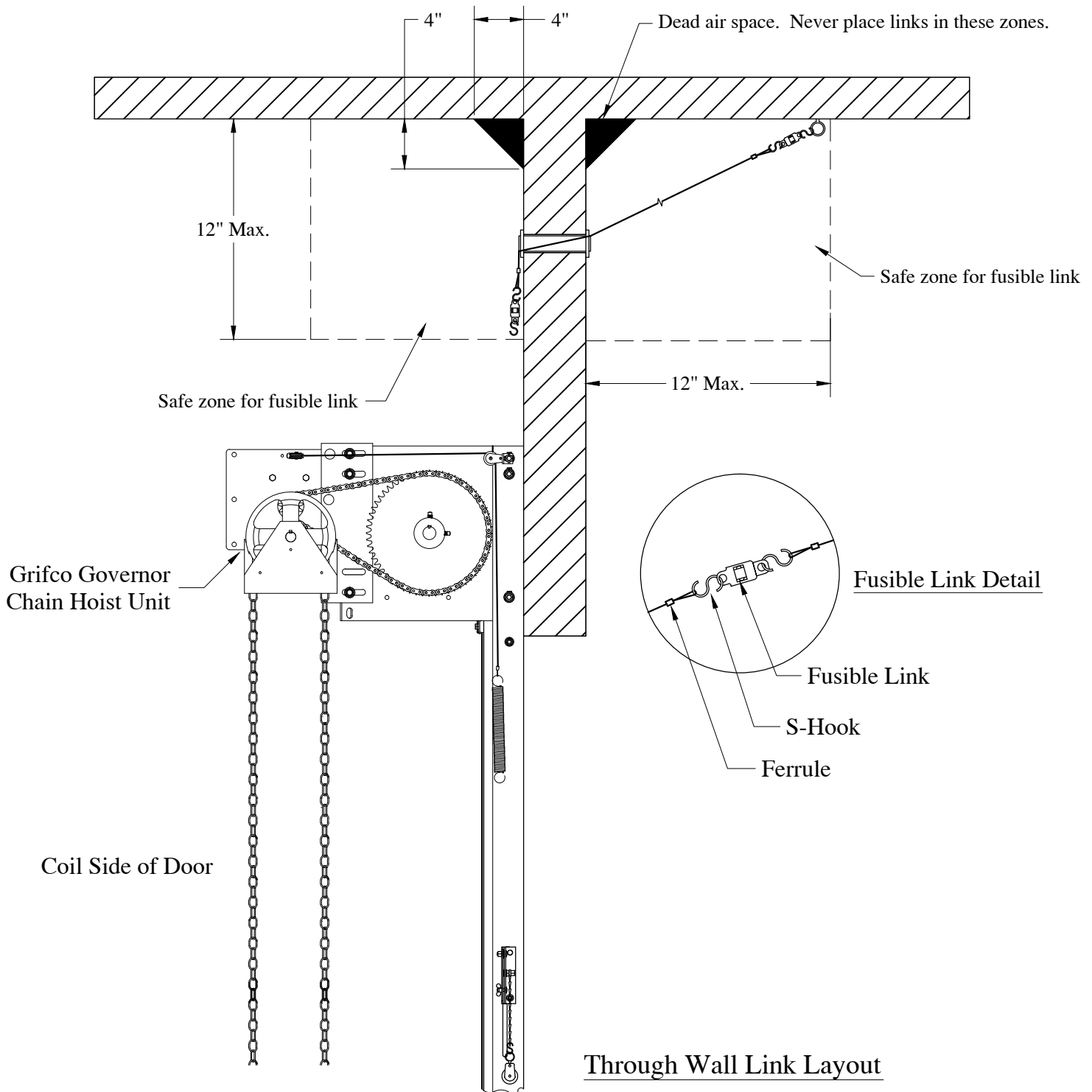

17.4 Raise test handle to 12 o'clock position. Install cable to fusible link on coil side of the door by looping cable end and setting with a ferrule. Route down through pulley on test handle and up to spring. Remove all slack in cable assembly being careful not to stretch spring. Loop end of cable and secure with crimped ferrule.

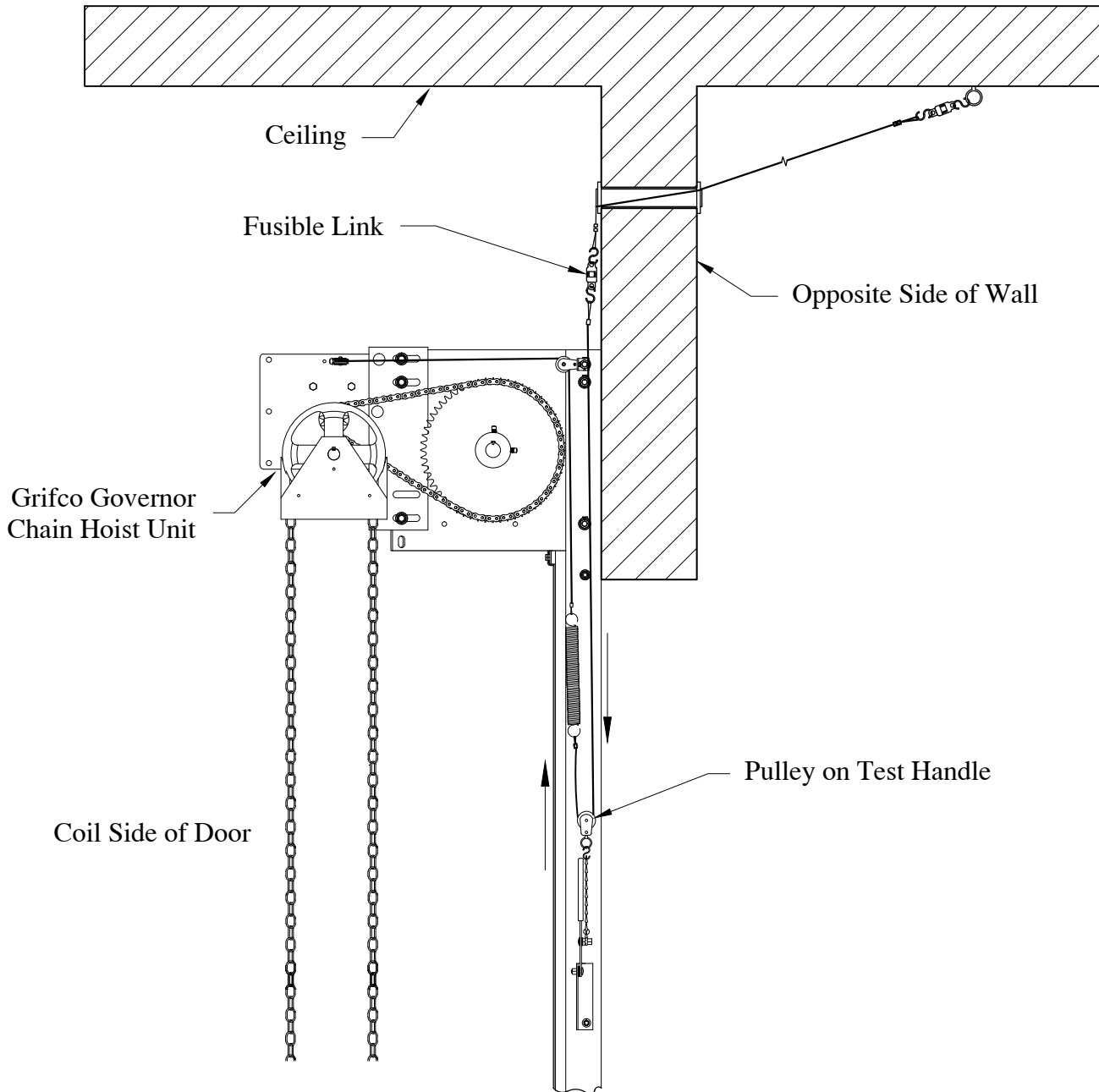

Through Wall Link Layout



17.5 Pull test handle down. Spring should stretch an overall length of 10 to 12 inches.

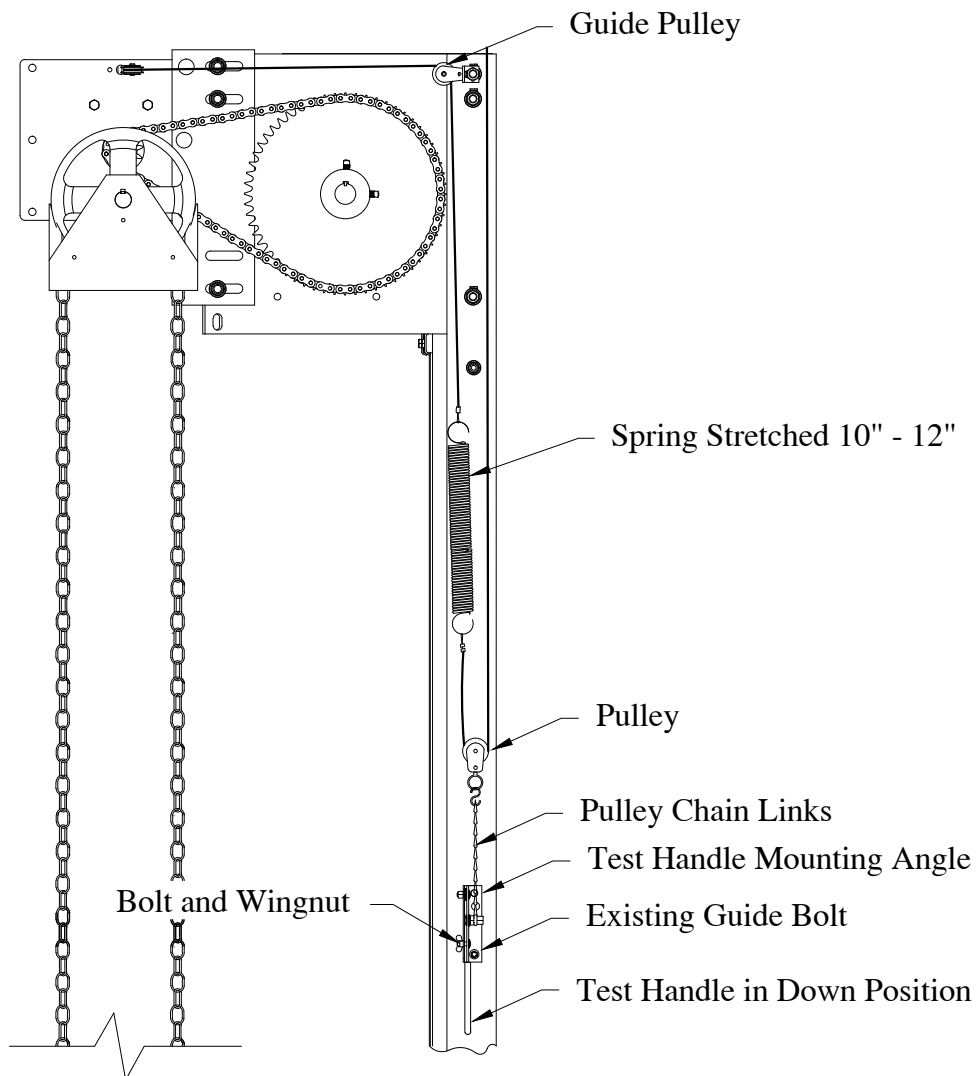

Cable, Spring and Test Handle Layout

17.6 Remove temporary rope or tie down installed in section 9.5 from governor brake arm. Spring should maintain sufficient tension to keep brake engaged if stretched as described in step 17.5.

## 18.0 DROP TEST AND RESET INSTRUCTIONS:

⚠ **Warning!! Before drop testing door be certain doorway is in sight and clear of people and obstructions.**

18.1 Hold test handle and remove the wing nut and carriage bolt, (or padlock) that secures the handle.

18.2 Raise test handle fully to relax hoist spring tension and the door will begin to self close. Door should typically close 6" - 12" per second. (NFPA recommends 6"- 24".)

⚡ **CRITICAL!** If door fails to "self close", refer back to page 14 section 13.0 of this manual under heading "Tensioning the Barrel." It may be necessary to release additional tension from the preload amount.

⚡ **CRITICAL!** If door closes slower than 6" per second or faster than 12" per second, refer to figure below for governor speed adjustments.

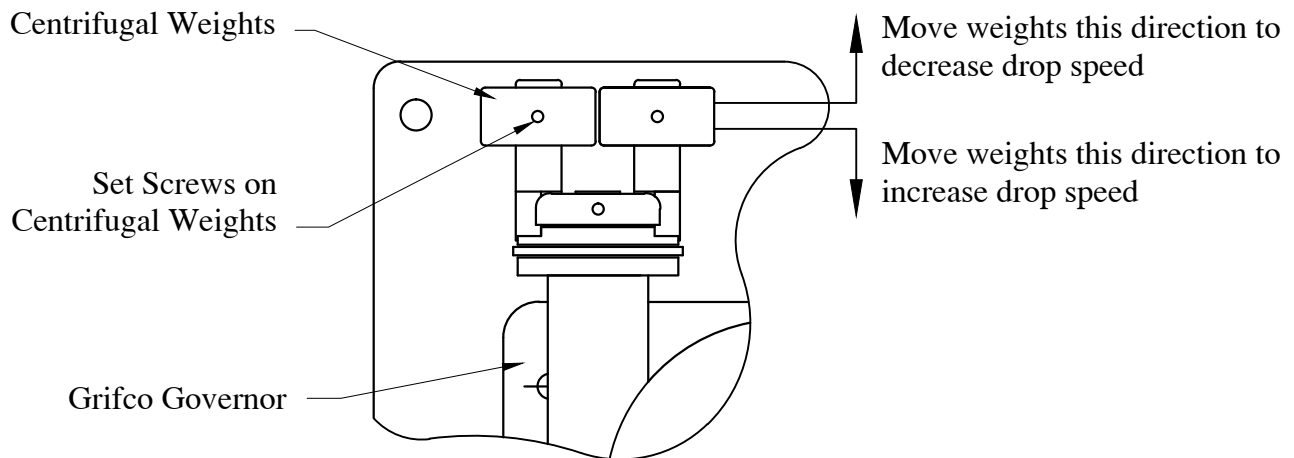

Governor Speed Adjustment

💡 **Note: Moving the centrifugal weights further out on their shafts increases braking and decreases curtain drop speed. Moving the weights further in on their shaft decreases braking and increases curtain drop speed.**

18.3 To reset, lower the handle and replace the carriage bolt and wing nut (or padlock).

💡 **It may be necessary to pull chain hoist chain slightly to engage brake lever arm.**

18.4 Complete provided drop test form only after test drop has been witnessed. Obtain witness signature. Refer to NFPA-80 for "Jurisdiction of Local Authority" and check local Fire Code to establish who must act as a witness for fire door test drops. Return copy of signed and completed form to ASTA via mail or fax - (770) 974-1455. NFPA-80 and other code bodies recommend annual drop testing of all fire doors. Additional drop test forms are available upon request by phone, fax or mail.

ASTA Door Corporation  
4255 McEver Industrial Drive  
Acworth, Georgia 30101

## 19.0 MAINTENANCE

- 19.1 Inspect door for cleanliness, fit and operation every two weeks.
- 19.2 Inspect guides, curtain and hood for wear or visible damage. Report any unusual wear or damage for immediate repair.
- 19.3 Inspect all fasteners for tightness and for damage. Report any damage or loose fasteners immediately for repair.
- 19.4 Inspect chain hoist mechanism and guide channels for unusual accumulations of dirt, grease or foreign matter that would hinder normal door operation or drop procedure.
- 19.5 Inspect fusible links, cables and release devices for dust, grease or foreign materials that may impede release or operation.
- 19.6 Immediately report and replace any fusible links that have grease, paint or foreign materials that will prevent separation.
- 19.7 NFPA-80 and other code bodies recommend annual drop testing of all fire doors. Drop testing is an important part of the preventative maintenance program.

- ✓ **WARNING!!** Individuals operating any rolling steel door must do so in a prudent and safe manner. Unsafe operation or allowing personell or property to pass through an opening when door is not at rest in its fully open position may result in personal injury, door damage or property damage. Always practice safe operating procedures and never stand in the path of a moving door.
- ✓ **WARNING!!** Wear protective gloves and eye wear when working on the door.
- ✓ **WARNING!!** If in doubt of the fitness or structural integrity of jambs, a qualified engineer must inspect the existing conditions before proceeding further.
- ✓ **WARNING!!** Guides are not intended or designed to act as structural reinforcement for existing jambs. Jamb surface must extend full height of wall angle.
- ✓ **WARNING!!** Installation of anchoring devices into unsound building material will result in product damage, personal injury, premature wear and product failure.
- ✓ **WARNING!!** Secure all loads to hoist equipment to prevent movement while hoisting. Do not allow personnel to ride hoist equipment. Stay off ladders and lifts until barrel and/or curtain have been hoisted to the final position of attachment. Serious personal injury will result from carelessness or lack of planning. Plan all moves carefully!
- ✓ **WARNING!!** It is essential that you use hoisting equipment of adequate stability and rated capacity to safely lift the barrel and headplate assemblies.
- ✓ **WARNING!!** Never exceed number of turns shown by more than one-half turn.
- ✓ **WARNING!!** Before drop testing door be certain doorway is in sight and clear of people and obstructions
- ✓ **WARNING!!** After correct tension is reached, the spring is under tension and extremely dangerous.
- ✓ **WARNING!!** Never place fingers near any moving parts while door is in operation.
- ✓ **WARNING!!** Adjustments or repairs to door should be performed only by mechanically experienced individuals who have the proper tools, instructions and a thorough understanding of the entire door assembly and its operation.

## 20.0 PAINTING

20.1 Curtain slats and hood feature finish coat polyester paint over baked on enamel primer and galvanized steel. Protective paint coats are not necessary unless desired. Guides and end brackets are factory coated with high quality primer which is compatible with most quality exterior grade paints.

20.2 REPAINTING THE DOOR: Wash surface thoroughly with a solution of trisodium phosphate (commonly called TSP). Buff surface lightly with an extra-fine-grade steel wool. Repair any rust or bare metal areas and coat with a zinc-based primer. Paint with premium-quality oil-based or latex exterior paint. Avoid use of solvents (mineral spirits can be used). Apply paint to small area of door to test for adhesion. If new paint does not chip, crack or bubble, apply to remainder of door. If in doubt about the correct paint system to use, contact a painting professional.

### ☑ **WARNING!! Do not Paint:**

- ☑ Axles, bearings or moving parts
- ☑ Wear surfaces on guides
- ☑ Stainless steel slide locks
- ☑ Bottom bar angles
- ☑ Brush seal, jamb seal or bottom astragal
- ☑ Chain hoist or chain hoist contact surfaces
- ☑ Governor hoist unit
- ☑ Safety warning labels
- ☑ Operational labels or placards
- ☑ Fusible links
- ☑ Cables

20.3 ASTA recommends that you closely follow paint manufacturer's recommendations for cleaning, preparing and applying paint to obtain best results.

# TROUBLE SHOOTING

PROBLEM	PROBABLE CAUSE	REMEDY
<input checked="" type="checkbox"/> Door will not close all the way to the floor.	Too much spring preload.	Open door fully and back tension off one hole at a time until satisfactory balance is achieved (Page 15, section 13.6).
<input checked="" type="checkbox"/> Door will not stay shut.		
<input checked="" type="checkbox"/> Door closes hard.		
<input checked="" type="checkbox"/> Door closes too fast.	Too little spring preload.	Open door fully and increase tension one hole at a time until satisfactory balance is achieved (Page 14).
<input checked="" type="checkbox"/> Door closes too slow.	Centrifugal weights require adjustment.	Refer to section 18.0 page 22. If problem still exists remove centrifugal weights completely.
<input checked="" type="checkbox"/> Curtain runs to one side.	Barrel not level.	Refer to installation of guides. Barrel must be level (Page 9).
	Curtain not centered.	Refer to installation of curtain (Page 12).
<input checked="" type="checkbox"/> Door is hard to move in either direction.	Guides too close together.	Verify that you have held the "X" dimension full height of guides (Page 4, section 6.7).
	Guides damaged.	Check for bent or damaged inner guides. Slats not centered in guides and headplates (Page 12).
	Key stock dragging	Verify that guides were spread when tightening guide bolts (Page 13, section 12.2).
<input checked="" type="checkbox"/> Door curtain "jumps" on way down or up.	Curtain binding on headplate or guides.	Check for bent or damaged inner guides.
		Verify that you have held the "X" dimension full height of guides (Page 4, section 6.8).
		Slats not centered in guides and headplates (Page 12).
<input checked="" type="checkbox"/> Door difficult to raise, will not stay open at head.	Broken spring.	Contact qualified ASTA Door technician to evaluate.
<input checked="" type="checkbox"/> Chain hoist "jumps."	Spring not sufficiently stretched.	Refer page 21.
	Holding brake not tight enough.	Refer to Holding Brake Adjustment (Page 15).
<input checked="" type="checkbox"/> Holding brake does not disengage when test handle is released.	Spring is overstretched.	Refer to Fusible Link System (Pages 18-21).
	Roller chain too tight.	Refer to Governor Chain Hoist Assembly (Page 11).



To insure proper identification of this door please complete the information below.

Door Model: \_\_\_\_\_

Door Size: \_\_\_\_\_ x \_\_\_\_\_

Serial Number : \_\_\_\_\_

Installed By: \_\_\_\_\_ Installation Date: \_\_\_\_\_

## LIMITED WARRANTY

### Commercial Rolling Steel Doors

ASTA Door Corporation warrants rolling steel doors, shutters and components to be free from defects in materials and workmanship for a period of five (5) years. Spring wire is warranted for one year. All warranty periods begin with the date of manufacture. ASTA obligations are strictly limited to repair or replacement of defective parts and components during the warranty period.

This limited warranty excludes: (1) rust caused by damages or scratching; (2) damage resulting from exposure to corrosive chemicals, corrosive fumes, condensation, water or fire; (3) damages caused by accident, improper use, negligent operation, improper installation, improper maintenance or normal wear; (4) shipping, installation or labor charges; (5) defects in paints or coatings used to finish door sections; (6) any product or component which is modified, altered, or not part of the original door, and (7) damages resulting from any circumstances beyond the direct control of ASTA Door Corporation.

In the event of a defective component, contact the dealer the door was purchased from within fifteen (15) days from discovery of the defect. ASTA reserves the right to inspect all products alleged to be defective and to verify eligibility of this limited warranty.

**THIS LIMITED WARRANTY EXCLUDES ANY LOSS OR DAMAGE NOT SPECIFICALLY UNDERTAKEN HEREIN, INCLUDING, WITHOUT LIMITATION, ANY consequential or incidental damages, such as death, injury, damages to property, or damages arising from loss of use of ANY PRODUCT OR FACILITY. All other warranties, expressed or implied, including any warranties of fitness for a PARTICULAR PURPOSE and of merchantability, are hereby expressly excluded.**

*This warranty is non-transferable.*

