



**R O L L I N G   S T E E L   D O O R S**

4255 McEver Industrial Drive  
Acworth, Georgia 30101  
Phone: (770) 974-2600 Toll Free: (800) 423-0659  
Fax: (770) 974-1455

# ***Installation Instructions***

---

**Models: FD341-FD340  
FD441-FD440  
Motor Operated (Micanan)  
Fire Door**

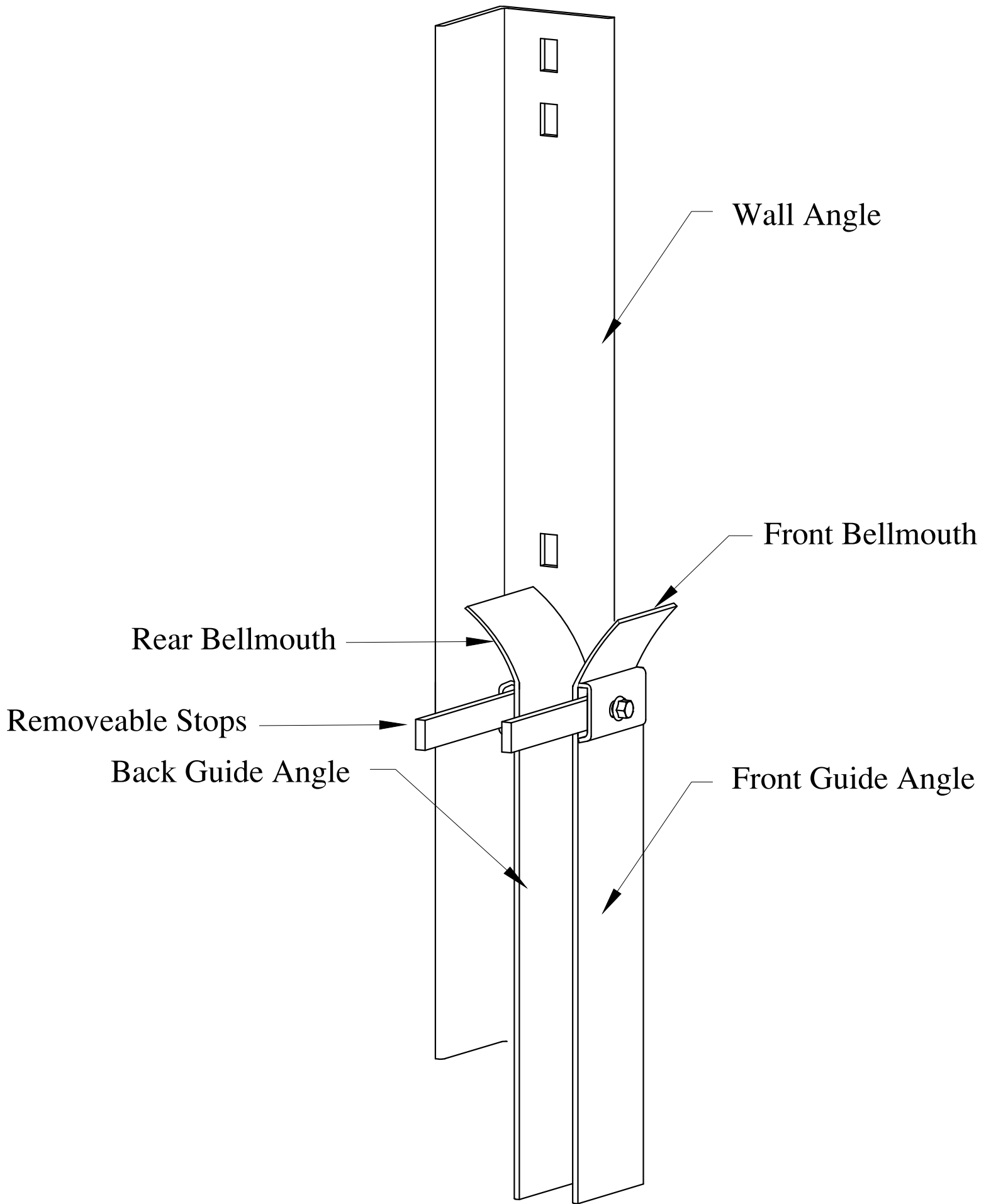

## TABLE OF CONTENTS

Guide Basics			
Sections:	1.0	General	Page 1
	2.0	Shipment Inspection	Page 1
	3.0	Checking Door Requirements	Page 1
	4.0	Existing Conditions	Page 1
	5.0	Preparation	Page 1
Section:	6.0	Guide Installation	Pages 2-5
Section:	7.0	Part Identification	Pages 6-8
Section:	8.0	Barrel Installation Procedure	Page 9
Section:	9.0	Micanan Motor Mounting	Page 10
Section:	10.0	Drive Shaft Governor /Sprocket Assembly	Pages 11-12
Section:	11.0	Curtain Installation	Page 13
Sections:	12.0	Bottom Bar Stop Installation	Page 14
	13.0	Guide Installation	Page 14
Section:	14.0	Tensioning the Barrel	Page 15
Section:	15.0	Hood Installation	Page 16
Sections:	16.0	Test Handle Mounting	Page 17
	17.0	Fusible Link Cable Assembly	Pages 17-19
Sections:	18.0	Motor Operator Limits	Page 20
	19.0	Drop Test and Re-set Instructions	Page 20
Sections:	20.0	Maintenance	Page 21
	21.0	Painting	Page 21
		Trouble Shooting	Page 22



# Installation Instructions

These instructions will show you how to install a ASTA Rolling Steel Fire Door. They are for the mechanically experienced person who has proper tools to perform the job. They are not meant to infringe upon or supersede any State or County building codes, fire codes or safety regulations.





**Safety first.** Safety warnings are clearly marked with a  **WARNING!!** symbol. Critical information is identified by a  **CRITICAL!** symbol. Tips are marked with a  symbol. Observe all of the guidelines, warnings, tips and critical information given in the instructions during the installation.

 **WARNING!! Wear protective gloves and eye wear when working on the door.**



**1.0 GENERAL:** Read and familiarize yourself with this entire manual before proceeding with installation. Contact ASTA for technical information at 4255 McEver Industrial Drive Acworth, Georgia 30101 Toll Free:(800) 423-0659

**2.0 SHIPMENT INSPECTION:** When the shipment arrives check for freight damage and missing items. Use packing list to determine completeness of shipment. If there is damage or a shortage is detected, contact ASTA immediately.

**3.0 CHECK DOOR REQUIREMENTS:** Use shop drawing to verify the following:

-  Width of opening
-  Height of opening
-  Headroom
-  Sideroom
-  Backroom at header

**4.0 EXISTING CONDITIONS**

-  Is floor level?
-  Is header level?
-  Are jambs plumb?

4.1 Inspect jambs and adjacent wall construction to verify that they are suitable for anchoring guide assemblies. ASTA is not responsible for the structural soundness of existing jambs and adjacent wall construction.

 **WARNING!! If in doubt of the fitness or structural integrity of jambs, a qualified engineer must inspect the existing conditions before proceeding further.**

 **WARNING!! Guides are not intended or designed to act as structural reinforcement for existing jambs. Jamb surface must extend full height of wall angle.**

 **WARNING!! Installation of anchoring devices into unsound building material will result in product damage, personal injury, premature wear and product failure.**

**5.0 PREPARATION**

5.1 Clean and sweep work area of any debris or objects that may interfere with installation or damage the curtain. Place guides and curtain on protective cardboard if possible.

5.2 Position all components on the floor in the approximate location they will be later assembled. Double check for completeness of shipment at this point.

**6.0 GUIDE INSTALLATION:** Fasteners for mounting guides are supplied by ASTA

**STEEL JAMBS**

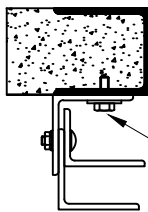
DETAIL VIEW	FASTENER SUPPLIED	DRILL SIZE	TAP SIZE
 <ul style="list-style-type: none"> <li>✓ Galvanized Washer</li> <li>✓ Hex Bolt</li> </ul>	<p>1/2" x 1-1/4" Hex Head Thread Cutting Screws</p> <p>3/4"-10 Bolt</p>	<p>29/64" Drill</p> <p>21/32" Drill</p>	<p>N/A</p> <p>3/4-10 UNC</p>

**CONCRETE/ FILLED BLOCK**

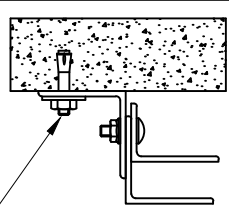
DETAIL VIEW	FASTENER SUPPLIED	DRILL SIZE	💡 NOTES
 <ul style="list-style-type: none"> <li>✓ Sleeve Type Expansion Anchor</li> <li>✓ Galvanized Washer</li> </ul>	<p>1/2" Sleeve Anchor</p> <p>3/4" Sleeve Anchor</p>	<p>1/2" Drill</p> <p>3/4" Drill</p>	<p>Do not drill holes closer than 4" to the edge of any masonry.</p>

**HOLLOW BLOCK/SOFT BRICK JAMBS**

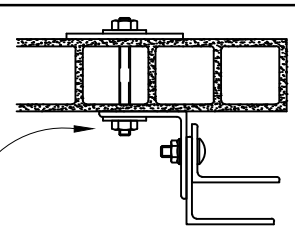
DETAIL VIEW	FASTENER SUPPLIED	DRILL SIZE	💡 NOTES
 <ul style="list-style-type: none"> <li>✓ 4 x 4 Crush Plate</li> <li>✓ Hex Nuts</li> <li>✓ Thru Bolt</li> <li>✓ Galvanized Washers</li> </ul>	<p>1/2" Thru Bolts</p> <p>3/4" Thru Bolts</p>	<p>1/2" Drill</p> <p>3/4" Drill</p>	<p>-Do not drill holes closer than 4" to the edge of any masonry.</p> <p>-Required: 4" x 4" Crush Plates under nut on opposite side of wall.</p>

**SHEETROCK JAMBS**

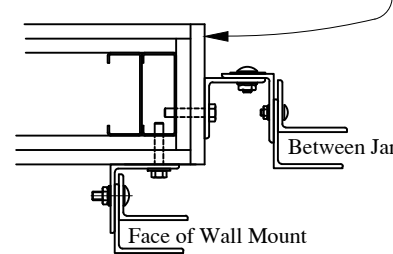
DETAIL VIEW	STEEL STUD	WOOD STUD
<p>Minimum Two Layers 5/8" Sheetrock</p>  <p>Between Jamb Mount</p> <p>Face of Wall Mount</p>	<p>1-3/8" x 3-5/8" x 14 gauge minimum</p>	<p>2" x 4", 2" x 6", or 2" x 8"</p>
	<ul style="list-style-type: none"> <li>✓ Drill 11/32" Pilot Hole</li> <li>✓ 3/8"-16 x 2" Type T Hex Head Tapping Screw</li> </ul>	<ul style="list-style-type: none"> <li>✓ Drill 1/4" Pilot Hole</li> <li>✓ 1/2" x 3" Hex Head, Lag Screw</li> </ul>

READ AND BE SURE THAT YOU COMPLETELY UNDERSTAND ALL OF THE STEPS AND WARNINGS AS OUTLINED PRIOR TO BEGINNING INSTALLATION.

- 6.1 Guides are shipped assembled and consist of a wall angle (the longest angle), back guide angle and front guide angle.
- 6.2 The existing jamb will determine the door guide configuration you will use:
  - "E" type guides: mount to steel and sheetrock jambs.
  - "Z" type guides: mount on masonry applications.
  - "J" type guides: between-jamb mounting.

**💡 Accurate Guide Installation: Mark a level reference point on each jamb to insure guides are installed level with each other. Measure from the reference marks on each jamb to the floor to achieve identical elevations. Wall angles are to be set on a level floor for upward expansion. Temporarily shim one side if necessary.**

- 6.3 Disassemble front and back guide angles from wall angles.
- 6.4 Measure guide angle legs to determine proper "X" dimension. Guide leg measurement will be 3", 3-1/2" or 4" depending on size of door.
- 6.5 E & Z guides: Mark center of opening width on floor. Measure 1/2 "X" dimension (shown on shop drawing). This establishes the outside face of wall angle.

**⚡ CRITICAL! The "X" Dimension is essential for proper door operation, and must be held constant from top to bottom.**

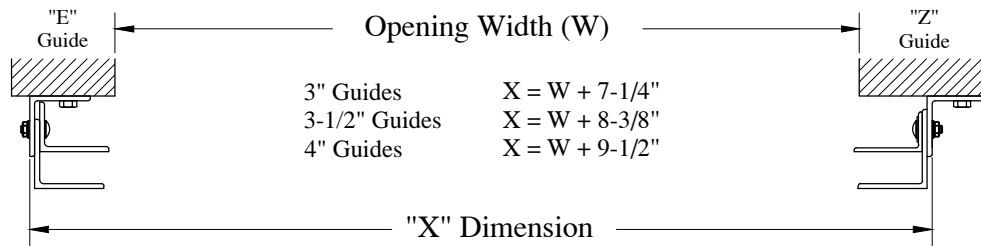

**E and Z Guide Clearances**

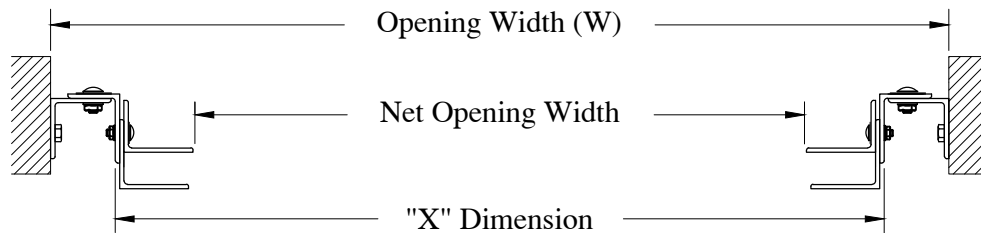

Net opening width = W - Tension side clearance - Drive side clearance

Tension Side Clearances		Drive Side Clearances	
3" Guides	= 6-1/2"		= 7-1/2"
3-1/2" Guides	= 7"		= 8"
4" Guides	= 7-1/2"		= 8-1/2"

**Standard J Guide Clearances**

If you plan to weld guides to steel jambs refer to weldment procedures for face of wall and in between jamb mounting, sections 6.8 and 6.9 on page 5.

6.6 Once appropriate fasteners and locations have been determined, drill holes and attach wall angle. Do not tighten fasteners until wall angle is plumb and at the desired elevation.

⚡ **CRITICAL!** Fire Door Fastener Location: This step is required by design and for Fire Door Label compliance. It must be strictly followed for proper expansion of fire door guides when exposed to heat and/or flame. All fasteners must be installed in the top of all slots.

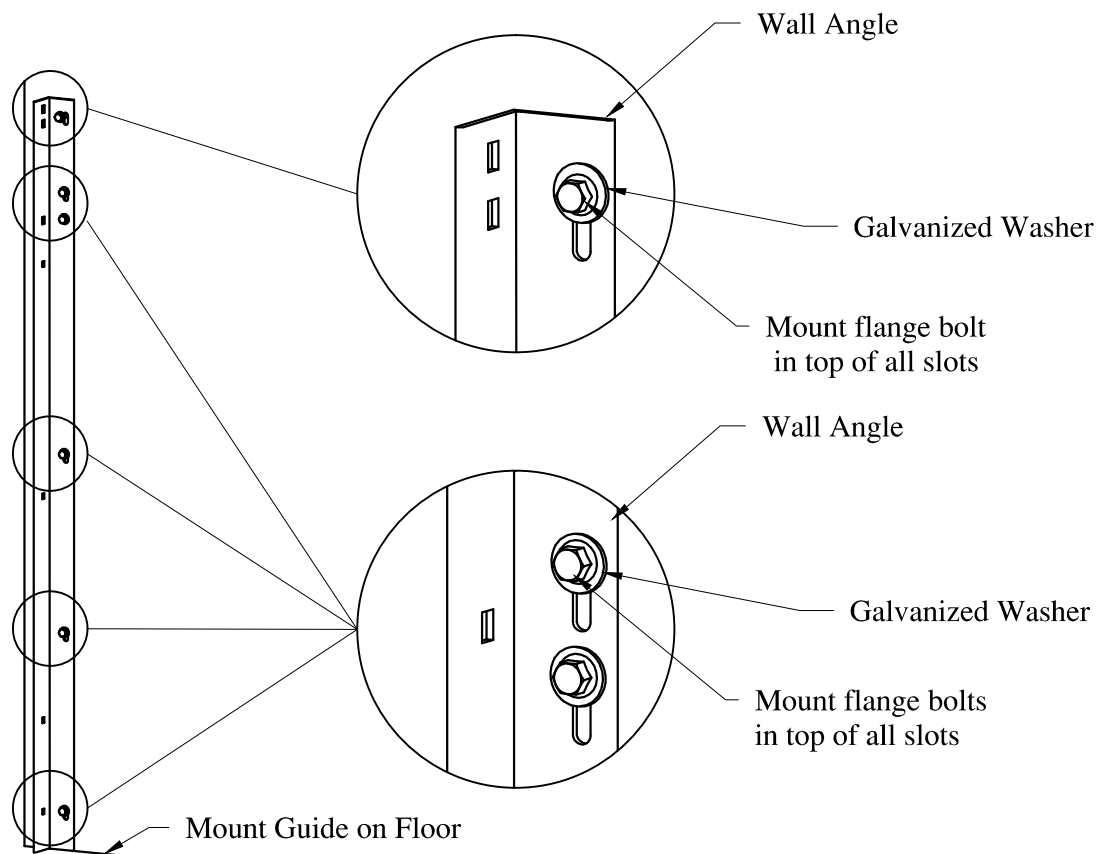

### Fire Door Fastener Location

6.7 Mount opposite wall angle, paying close attention to the "X" dimension. This guide may be set by using a tape measure, provided the first guide set is installed correctly. On doors over 10' in height, use several reference points to determine an accurate "X" dimension top to bottom.

⚡ **CRITICAL!** Review all fastener locations, elevations of guides and "X" dimension before proceeding. ASTA will not warranty any door that does not have guides set plumb, level with each other, with incorrect spacing between guide faces or with fasteners set in improper locations.

6.8 Weldment Procedure for Face of Wall Mounted Guides:

⚡ **CRITICAL!** Use E6010/E6011 electrodes or electrodes of equivalent strength.

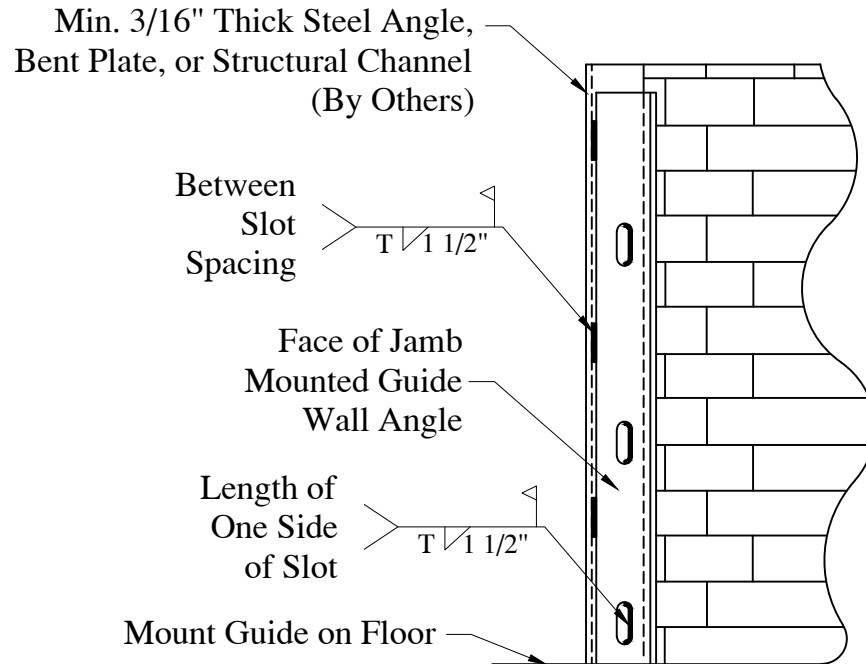

6.9 Weldment Procedure for Between Jamb Mount:

⚡ **CRITICAL!** Use E6010/E6011 electrodes or electrodes of equivalent strength.

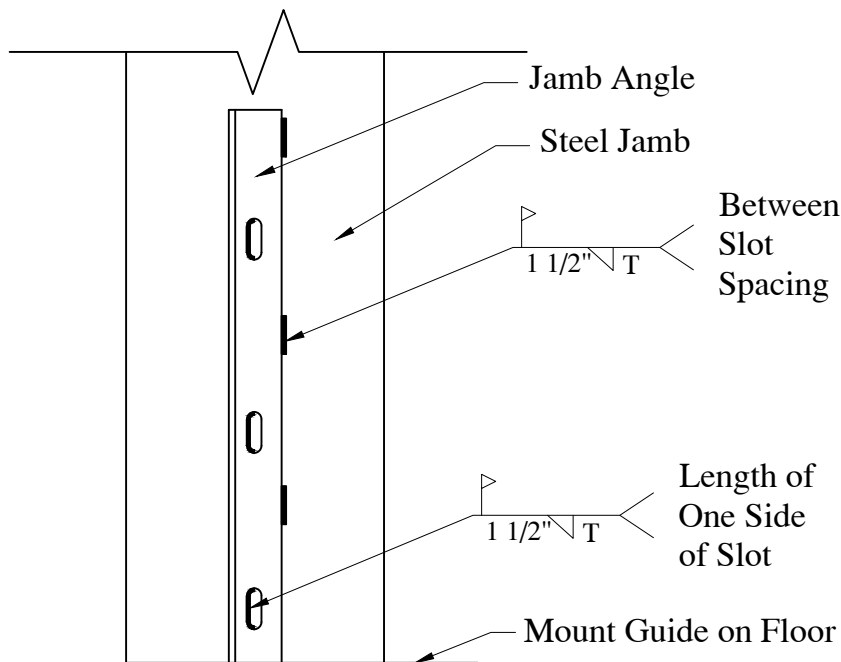



## 7.0 PART IDENTIFICATION

7.1 Identify drive side and tension side head plate. Drive side head plate must match drive side shown in shop drawing.

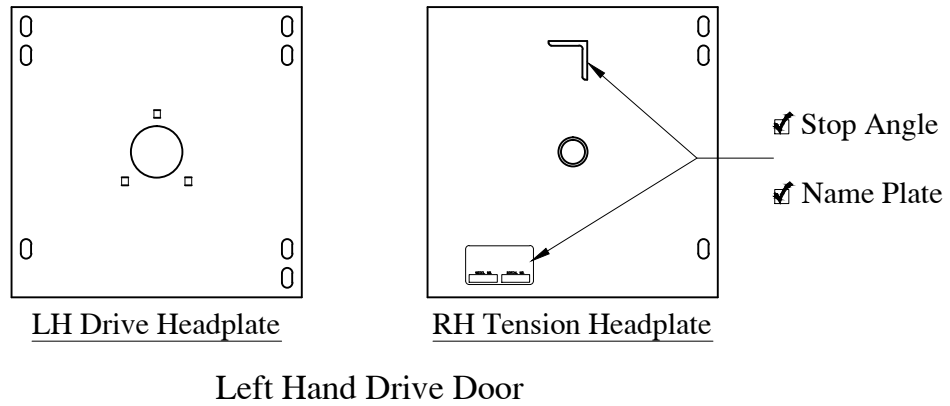
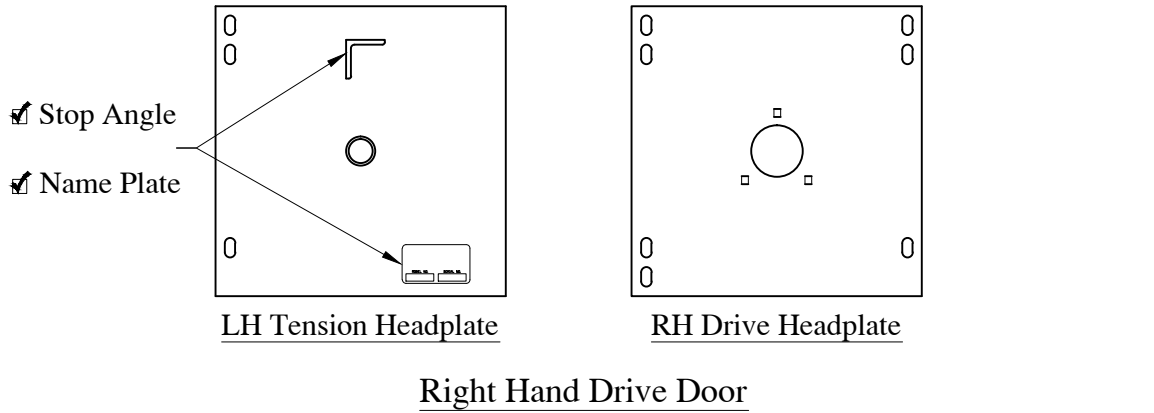

7.2 Barrel ends are identified by drive side and tension side.

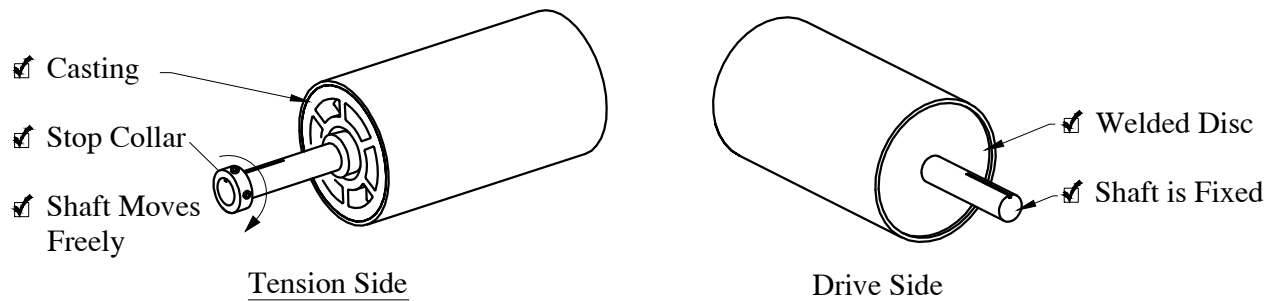

### 7.3 Tension Side Assembly.

 **This process is easier if you elevate the barrel to waist height.**

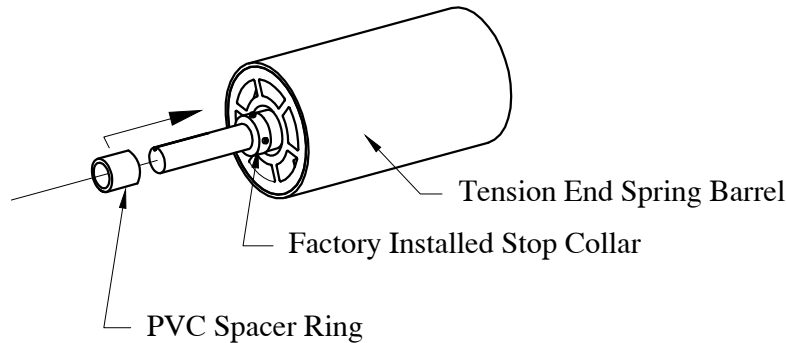

✔ Identify PVC spacer ring and slide onto end of shaft to stop collar.

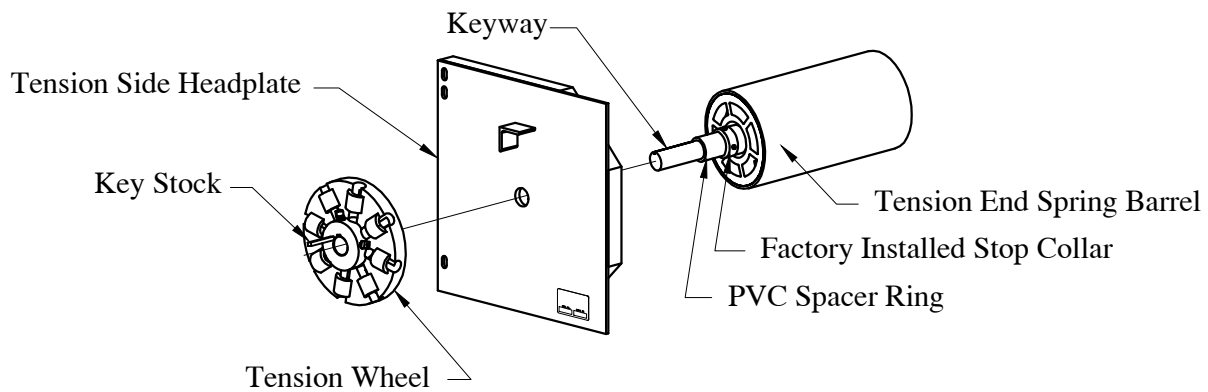

- ✔ Slide tension side headplate onto shaft.
- ✔ Slide tension wheel onto shaft until flush with end of shaft.
- ✔ Insert key stock and tighten set screws on tension wheel.
- ✔ Slide headplate out so that it rests against tension wheel.

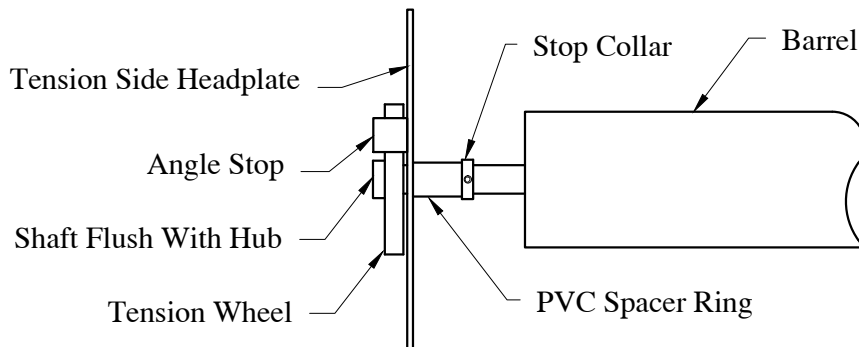

- ✔ Slide PVC spacer out to headplate.
- ✔ Slide stop collar to PVC spacer ring and tighten set screws in stop collar.

7.4 **Drive End Assembly:** Locate bearing assembly and bolt to inside face of drive side headplate with three 5/16" x 1" carriage bolts and nuts. Slide the drive side headplate onto drive shaft.

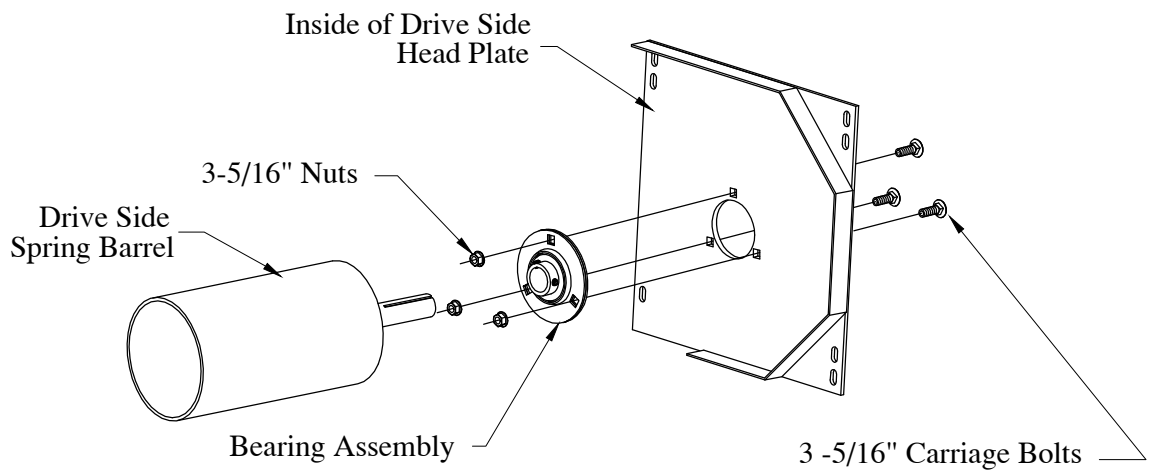

## 8.0 BARREL INSTALLATION PROCEDURE

- ✔ **WARNING!!** Secure all loads to hoist equipment to prevent movement while hoisting. Do not allow personnel to ride hoist equipment. Stay off ladders and lifts until barrel and/or curtain have been hoisted to the final position of attachment. Serious personal injury will result from carelessness or lack of planning. Plan all moves carefully!
- ✔ **WARNING!!** It is essential that you use hoisting equipment of adequate stability and rated capacity to safely lift the barrel and head plate assemblies.

8.1 Carefully raise barrel assembly into position to bolt headplates to wall angles. Head plates mount to inside face of wall angles with 1/2" x 1" carriage bolts. Wall angle may be punched for two or three bolts. Use all bolts provided. Bolts are inserted from inside of headplate facing out. Fasten nuts to bolts on outside of wall angle.

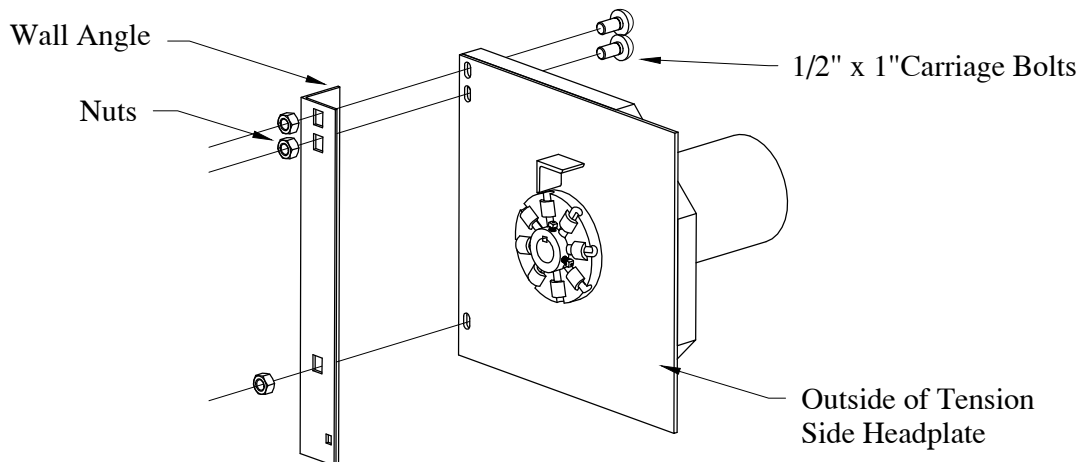

Tension Side Assembly

⚡ **CRITICAL!** Do not proceed unless barrel is level.

8.2 Once barrel is level, tighten all fasteners securely.

8.3 Check barrel rotation. Barrel should turn freely without binding.

💡 **At this time double check hood length. Hood length measurement should be approximately 1/2" shorter than the distance between headplates to allow for proper expansion.**

💡 **Measure distance between drive side and tension side headplates at the wall and at the front of the headplates. Square the headplates by obtaining same dimension at wall and at front of headplate. When headplates are square tighten bearing set screws.**

## 9.0 Micanan Motor Mounting

9.1 Motor operator bracket mounts on outside face of headplate.

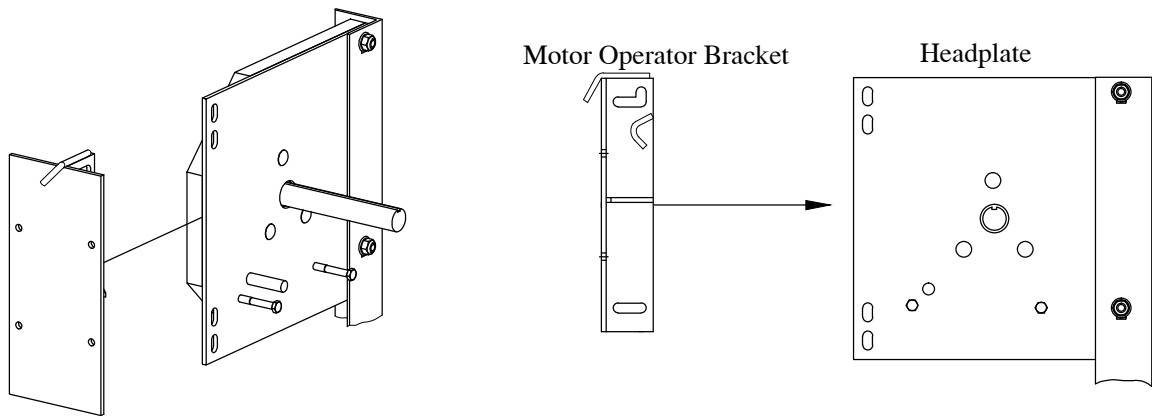

9.2 Secure motor operator bracket to headplate with two 1/2" x 1" carriage bolts.

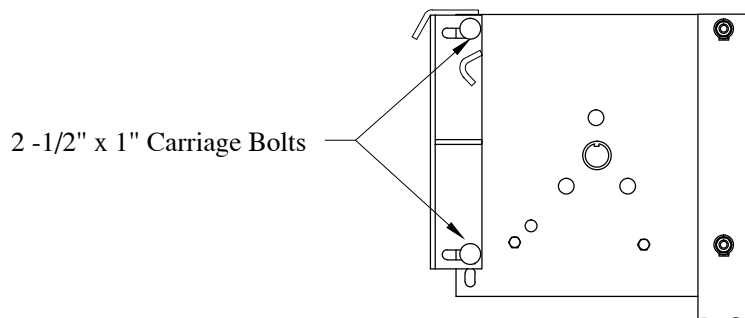

9.3 Secure motor to operator bracket using four 3/8" x 1-1/4" bolts and nuts.

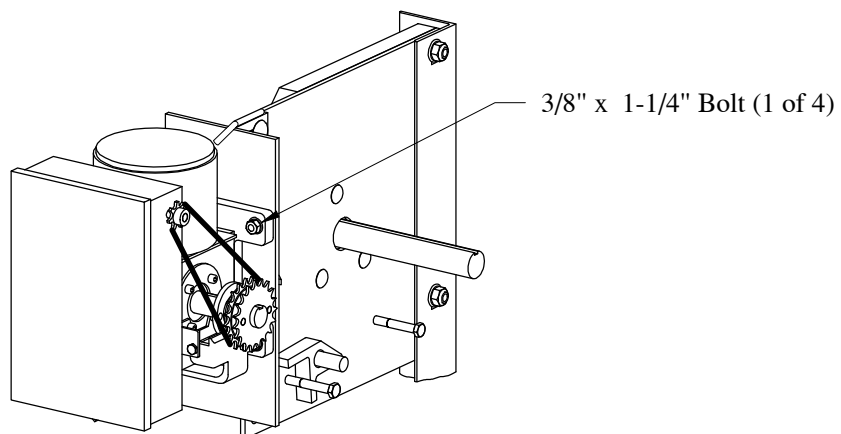

## 10.0 Drive Shaft Governor / Sprocket Assembly

10.1 Install two 1" bronze washers onto drive shaft, followed by viscous governor, key stock, and stop collar. Slide all components loosely against headplate and tighten set screw in stop collar.

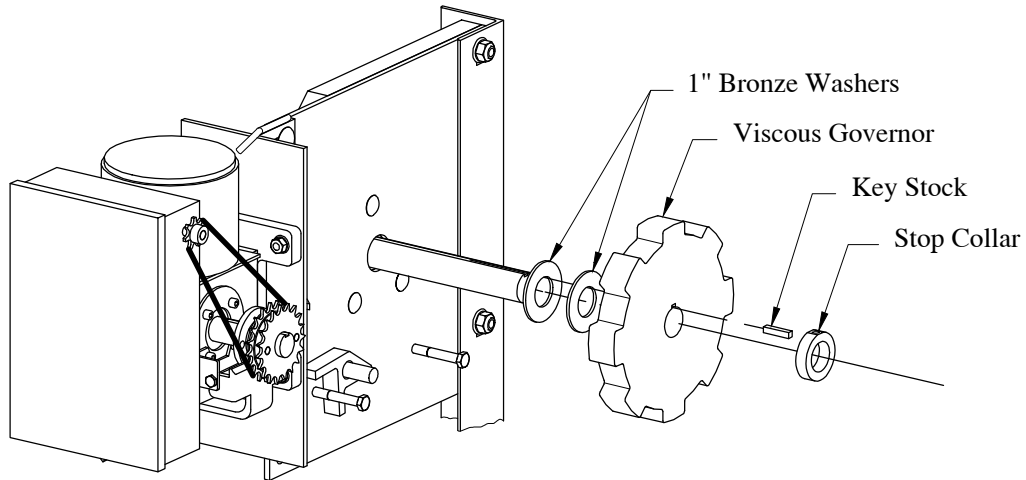

10.2 Install drive sprocket to drive shaft. Line up with output sprocket of motor operator and insert key stock.

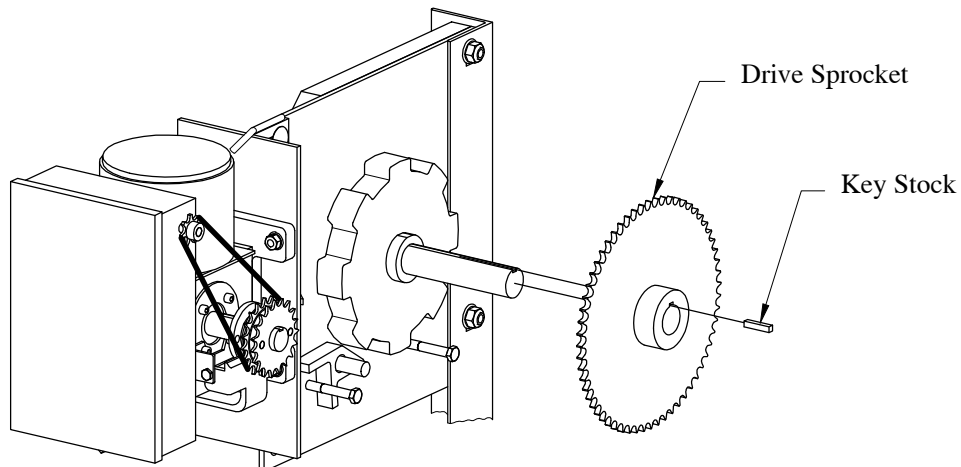

10.3 Install drive chain from operator output sprocket to drive shaft sprocket. Adjust drive shaft sprocket to achieve precise alignment. Remove all but 1/2" slack in roller chain and tighten operator bracket bolts.

 **NOTE: Use existing vertical slot or drill hole thru motor bracket and headplate. Insert bolt and tighten to lock operator bracket in place. THIS IS EXTREMELY IMPORTANT TO PREVENT CHAIN FROM SLACKENING.**

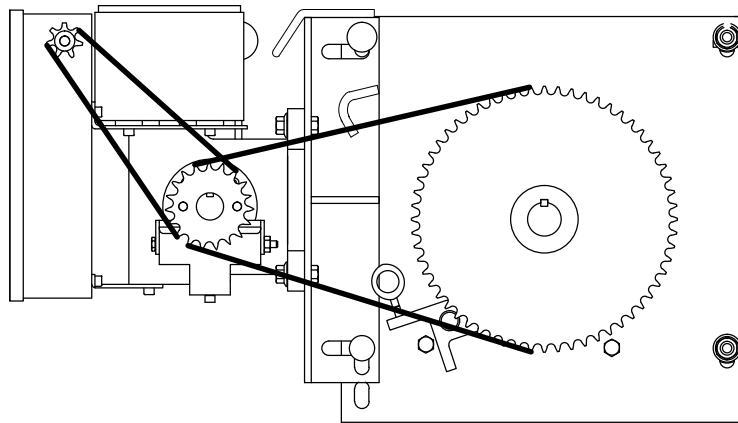

10.4 Drop Hammer is secured in place with temporary nylon tie. Do not cut tie. Do not connect cables.

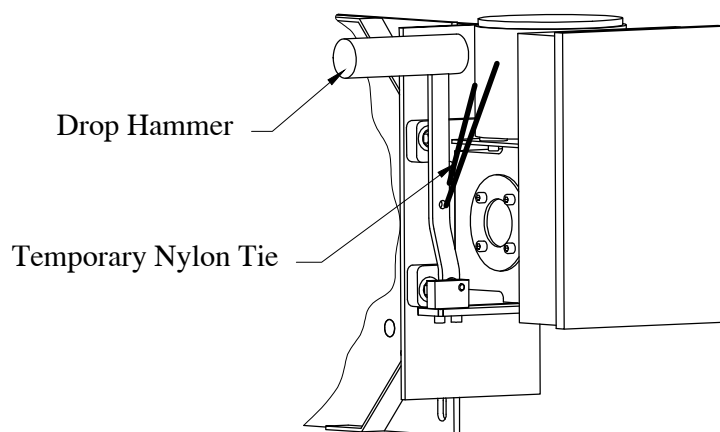

 **NOTE: At this time you may install temporary power and supplied 3 button station to transfer curtain to barrel in next step of the installation process.**

## 11.0 CURTAIN INSTALLATION

**💡 REMINDER:** Before installing curtain, note the number of preload turns written on the barrel and record that number in the space provided on page 15 section 14.0. After curtain installation, spring barrel will be covered by curtain and preload turn number written on barrel will no longer be visible.

11.1 Secure curtain to hoist and lift into place directly under barrel assembly.

11.2 Use a minimum of two Straight Eye Nylon Slings, with a minimum working rating of 5,000 pounds per sling, to encircle barrel and curtain. Fasten ends of slings together with Screw Pin Chain Shackles with a minimum working rating of 10,000 pounds per shackle.

11.3 Lower curtain to rest in slings.

**⚡ CRITICAL!** If barrel has rings, slings must pass over top of rings.

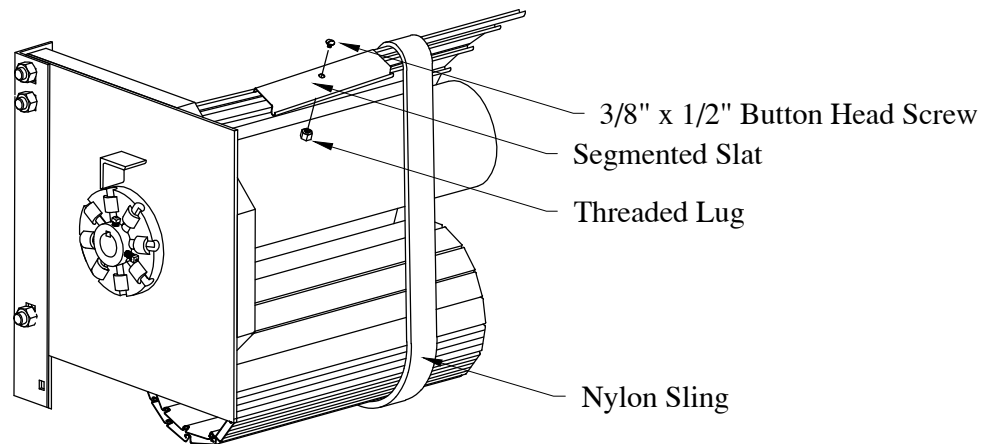

Slings The Curtain

**💡 NOTE:** Hoisting equipment may be used at this point to lift curtain slightly, allowing barrel to be rotated with chain hoist to help alignment of fastening points.

11.4 Clamp two curtain attachment segments directly to slings with vise grips. Operate motor with 3-button station to pull curtain up and over the top of barrel.

11.5 Attach curtain segments to lugs (6" and larger barrels) or to welded nuts on rings (4" barrels) with 3/8"x 1/2" button head screws. Do not over tighten.

11.6 Transfer curtain from sling to barrel with use of motor operator. Center curtain as it is being slowly wound onto barrel. Use winding bars at each curtain edge to adjust slats to center. Wind curtain until bottom bar angle is approximately 6" below headplates.

**⚠ WARNING!!** Leave slings in place for now as a safety precaution.



## 12.0 BOTTOM BAR STOP INSTALLATION

12.1 Install front and rear bottom bar stops. Secure with 5/16" x 1/2" hex head machine bolts.

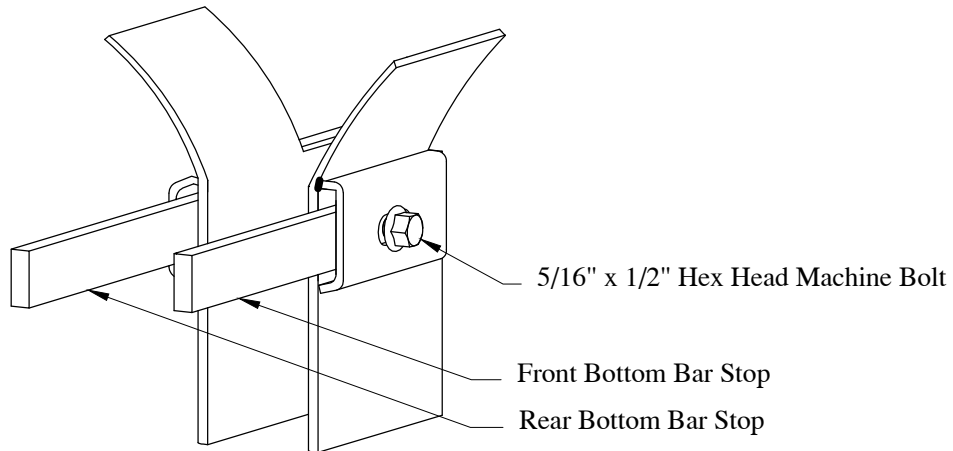

## 13.0 GUIDE INSTALLATION

13.1 Raise one guide assembly (front & back angles) into position for final attachment and align for bolting. Assemble using supplied fasteners. Bolts may be inserted from either side, depending upon preference.

13.2 As you tighten guide bolts, spread guides apart using winding bars or hammer claws for maximum throat width. Start at the top and work your way down.

## 14.0 TENSIONING THE BARREL

- 14.1 Mark starting location of tensioning wheel on head plate with chalk or marker for use as a reference while winding. At this time, refer to the specified preload number previously recorded. Insert one winding bar into an uppermost lug in tensioning wheel and pull down evenly. Lock tension wheel by inserting second winding bar or tension pin into uppermost available lug.

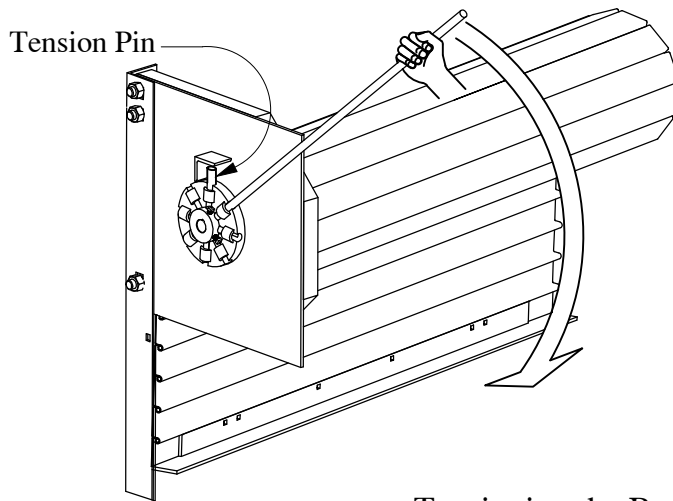

Preload Amount	
<input type="text"/>	Turns

Tensioning the Barrel

- ✓ **WARNING!! Never exceed number of turns shown by more than one-half turn.**
- ✓ **WARNING!! Use solid steel winding bars. Be certain that winding bar diameter matches lug hole size on the tension wheel and is a minimum of 18" long. Be sure that the bar is inserted fully into the winding lug. Use of improper or undersized bars will result in component failure and cause serious personal injury or death.**
- ✓ **WARNING!! Keep your head and body out of line with the winding bars. Always maintain a secure footing and balance. Firmly grasp the winding bars and be braced to resist strong forces whenever winding springs.**
- ✓ **WARNING!! From this point onward, the spring is under tension and extremely dangerous.**

- 14.2 When proper preload is established, lock tensioning wheel by placing the tension pin into appropriate casting lug, then easing wheel back with winding bar to let the tension pin rest on the angle iron stop.
- 14.3 Double check that bottom bar stops have been securely installed. Do not release sprocket disconnect lever arm.
- 14.4 Raise curtain to full open with bottom bar angle touching stops. Install vise grips on guides 3" - 5" below bellmouths.

## 15.0 HOOD INSTALLATION

- 15.1 ONE PIECE HOOD: Center hood between headplates and fasten using 1/4" x 3/4" long hex head self drilling screws. Mount all fasteners near outside edge of expansion slots to allow for proper expansion.

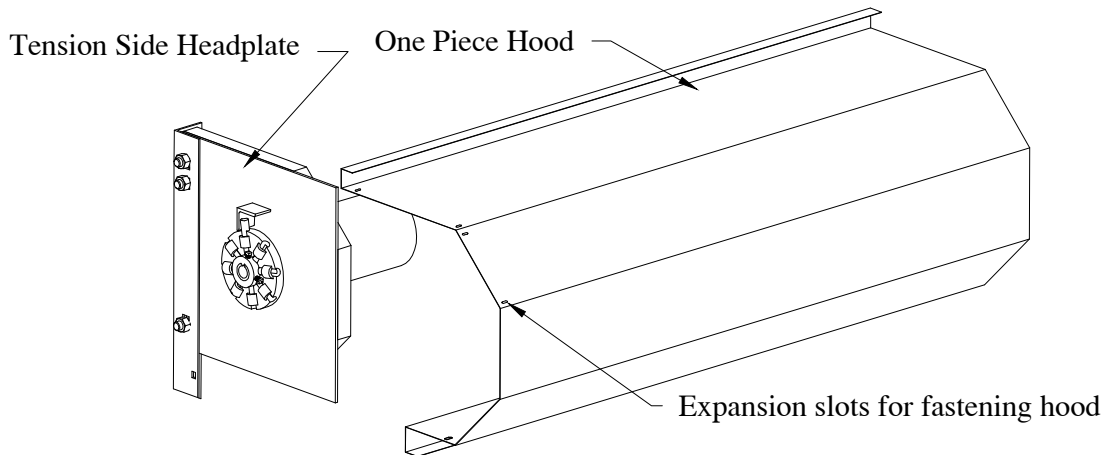

- 15.2 CENTER HOOD SUPPORT: Doors with two piece hoods are designed to be butt joined at the center of the door on a center hood support. Snap a chalk line from the top of each headplate. Find and mark the center on the chalked line between the headplates. Center hood support is to be centered in the opening with its top flush with chalk line. Attach center hood support to wall with fasteners suitable for wall construction (ASTA does not provide these fasteners).

- 15.3 ATTACHING MULTIPLE HOOD: Center hoods between headlates and butt-join on center hood support. Fasten with 1/4" x 3/4" hex head self drilling screws. Mount all fasteners near outside edge of expansion slots to allow for proper expansion.

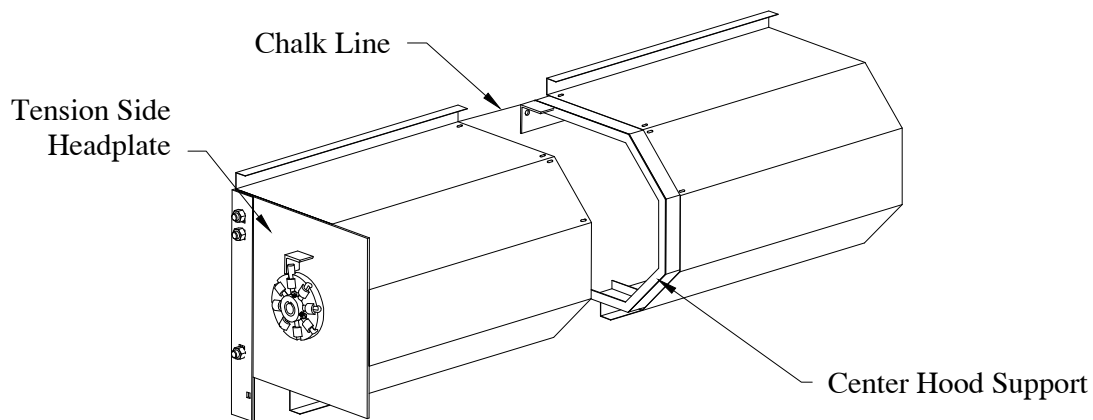

## 16.0 Test Handle Mounting

16.1 Mount test handle assembly using one existing guide to guide bolt installed with front and back guides.

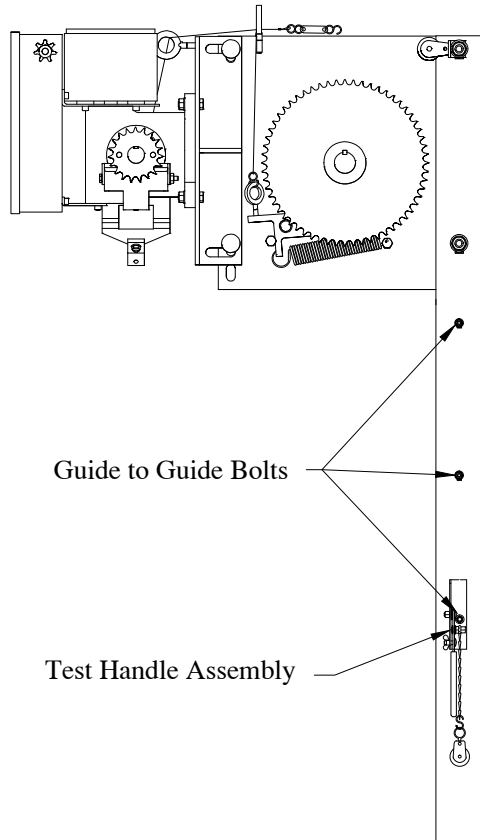

## 17.0 Fusible Link Cable Assembly

17.1 One section of cable will run from sprocket disconnect arm, through eyebolts and down to viscous governor catch. This cable assembly will be pre-constructed at factory.

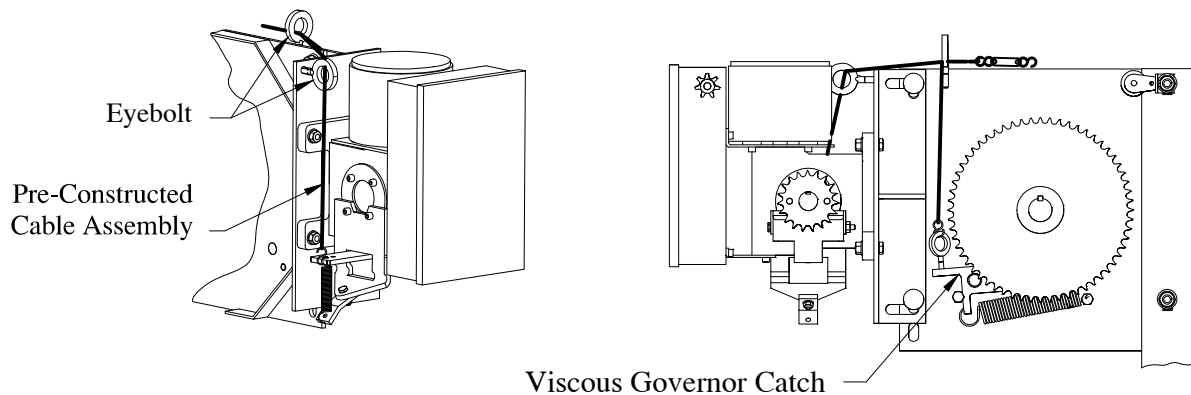

17.2 Connect factory constructed cable assembly to hole in drop hammer arm (cut temporary nylon tie). Do not attach second cable to viscous governor catch at this time. Install cable to turnbuckle, and test handle pulley as shown. Adjust turnbuckle to have enough cable tension to fully raise drop hammer and disconnect lever assembly.

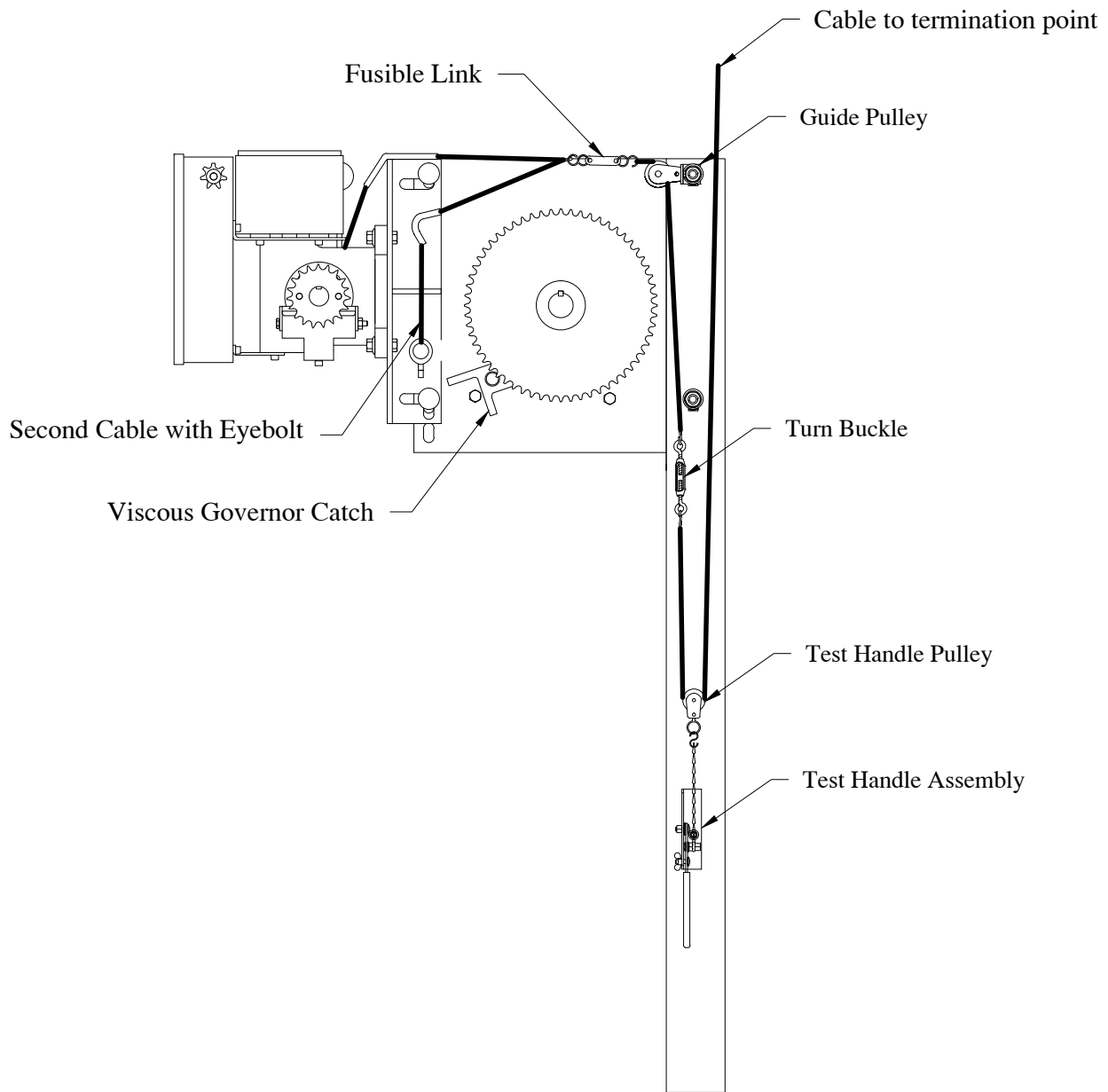

17.2a Finally, install second cable eyebolt to viscous governor catch with enough tension to keep it fully disengaged.

17.3 FUSIBLE LINKS: One fusible link is required within 12" of the ceiling opposite the coil side of the door. Another fusible link is a "link" in the cable located within 12" of the ceiling on the coil side of the door. S-hooks are provided to connect fusible links to loops in cable ends and are to be secured with ferrules. Route cable and fusible links in such a way that the release of the cable or the separation of any fusible link will release motor release arm.

⚡ **CRITICAL!** Refer to NFPA-80 for placement guidelines and check local code requirements before completion.

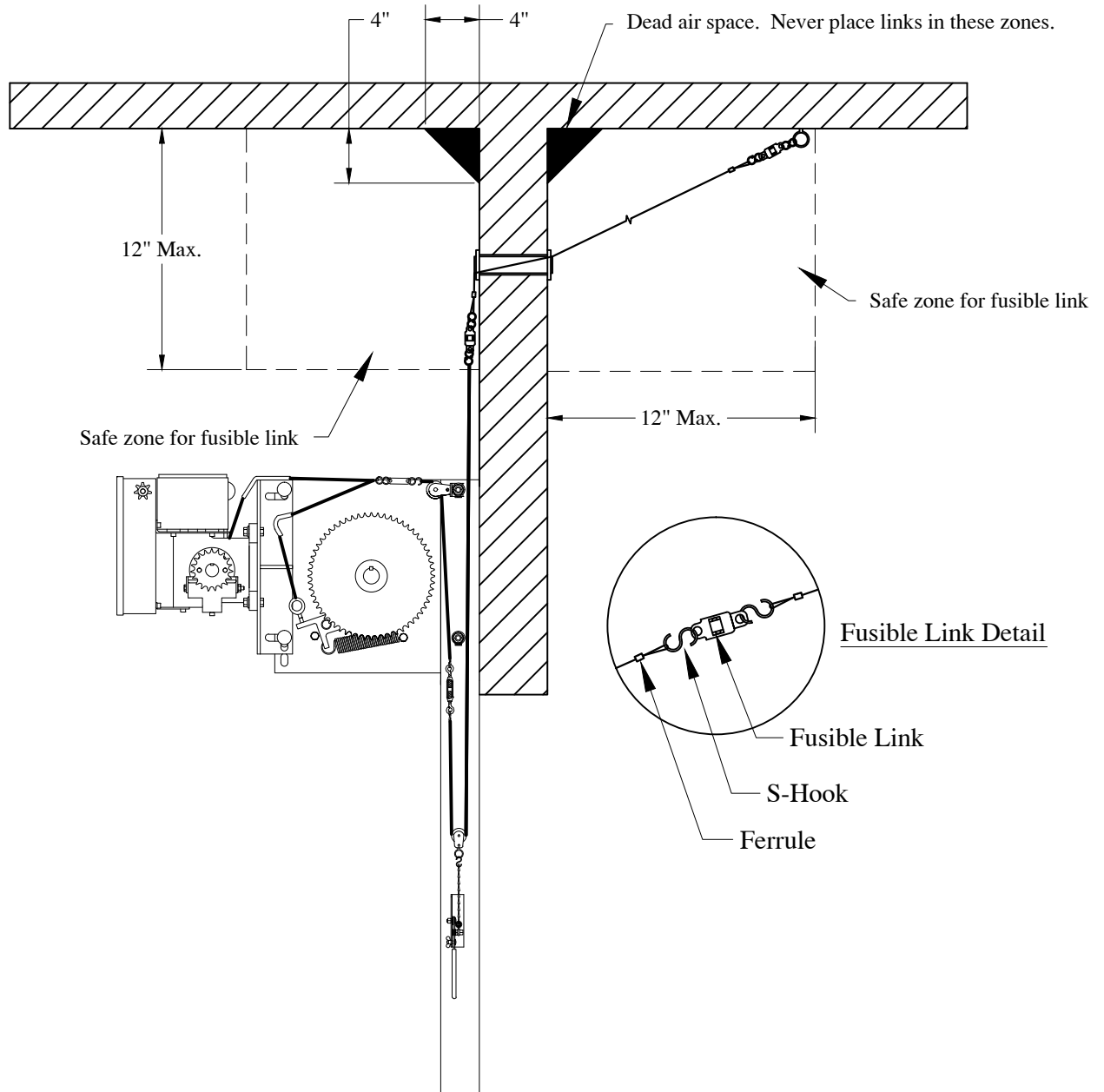

Through Wall Link Layout

## 18.0 Motor Operator Limits

- 18.1 Using 3-button station set open and close limits per manufacturer instructions. Once open and close limits have been set, raise curtain to fully open position resting against bottom bar stops.

## 19.0 DROP TEST AND RESET INSTRUCTIONS:

⚡ **Warning!!** Before drop testing door be certain doorway is in sight and clear of people and obstructions.

- 19.1 Securely install a vise grip to each guide assembly approximately 6" below bottom bar stops to catch curtain.

- 19.2 Hold test handle and remove wing nut and carriage bolt, (or padlock) that secures the handle.

- 19.3 Raise test handle fully to relax cable assembly.

⚡ **CRITICAL!** Curtain will not yet descend from header. Door assembly is in a balanced state as a result of previously applied pre-load.

- 19.4 Slowly back off tension at tension wheel until curtain descends from header and comes to rest on vise grips. Re-install tension pin at this location.

⚡ **CRITICAL!** With test handle in up position, cable assembly is released allowing viscous governor catch to engage. Governor should now control descent of door.

- 19.5 Re-engage test handle in down position and secure with bolt. Raise curtain to its open position. REMOVE PREVIOUSLY INSTALLED VISE GRIPS.

- 19.6 Raise test handle fully to relax cable assembly and the door will begin to self close. Door should typically close an average of 6" - 12" per second. (NFPA recommends 6" - 24" per second)

⚡ **CRITICAL!** If door fails to fully close, repeat step 19.4. It may be necessary to release more pre-load to allow the door to fully close to floor.

⚡ **CRITICAL!** If door self closes at a rate faster than 24" per second, raise door and apply additional pre-load.

- 19.7 Once desired close rate is established, re-engage test handle in down position and secure with bolt.

## 20.0 MAINTENANCE

- 20.1 Inspect door for cleanliness, fit and operation every two weeks.
- 20.2 Inspect guides, curtain and hood for wear or visible damage. Report any unusual wear or damage for immediate repair.
- 20.3 Inspect all fasteners for tightness and for damage. Report any damage or loose fasteners immediately for repair.
- 20.4 Inspect chain mechanisms and guide channels for unusual accumulations of dirt, grease or matter that would hinder normal door operation or drop procedure.
- 20.5 Inspect fusible links, cables and release devices for dust, grease or foreign materials that may impede release or operation.
- 20.6 Immediately report and replace any fusible links that have grease, paint or foreign materials that will prevent separation.

## 21.0 PAINTING:

- 21.1 The curtain slats and hood feature finish coat polyester paint over baked on enamel primer and galvanized steel. Protective paint coats are not necessary unless desired. Guides and end brackets are factory coated with high quality primer, which is compatible with most quality exterior grade paints.
- 21.2 **REPAINTING THE DOOR:** Wash surface thoroughly with a solution of trisodium phosphate (commonly called TSP). Buff surface lightly with an extra-fine-grade steel wool. Repair any rust or bare metal areas and coat with a zinc-based primer. Paint with premium-quality oil-based or latex exterior paint. Avoid use of solvents (mineral spirits can be used). Apply paint to small area of door to test for adhesion. If new paint does not chip, crack or bubble, apply to remainder of door. If in doubt about the correct paint system to use, contact a painting professional.

### ☑ **WARNING!! Do not Paint:**

- ☑ Axles, bearings or moving parts
- ☑ Wear surfaces on guides
- ☑ Stainless steel slide locks
- ☑ Bottom Bar angles
- ☑ Brush seal, jamb seal or bottom astragal
- ☑ Safety warning labels
- ☑ Operational labels or placards
- ☑ Fusible links
- ☑ Cables

- 21.3 ASTA recommends that you closely follow paint manufacturer's recommendations for cleaning, preparing and applying paint to obtain best results.



# TROUBLE SHOOTING

PROBLEM	PROBABLE CAUSE	REMEDY
<input checked="" type="checkbox"/> Door will not close all the way to the floor.	Too much spring preload.	Open door fully and back tension off one hole at a time until satisfactory balance is achieved (Page 15, 22).
<input checked="" type="checkbox"/> Door will not stay shut.		
<input checked="" type="checkbox"/> Door closes hard.		
<input checked="" type="checkbox"/> Door closes too fast.	Too little spring preload.	Open door fully and increase tension one hole at a time until satisfactory balance is achieved (Page 14).
<input checked="" type="checkbox"/> Curtain runs to one side.	Barrel not level.	Refer to installation of guides. Barrel must be level (Page 9).
	Curtain not centered.	Refer to installation of curtain (Page 13).
<input checked="" type="checkbox"/> Door is hard to move in either direction.	Guides too close together.	Verify that you have held the "X" dimension full height of guides (Page 3).
	Guides damaged.	Check for bent or damaged inner guides. Slats not centered in guides and headplates (Page 3).
	Keystock dragging	Verify that guides were spread when tightening guide bolts.
<input checked="" type="checkbox"/> Door curtain "jumps" on way down or up.	Curtain binding on headplate or guides.	Check for bent of damaged inner guides.
		Check that "X" dimension has been held at headplates.
		Slats not centered in guides and headplates (Page 13).
<input checked="" type="checkbox"/> Door difficult to raise, will not stay open at head.	Broken spring.	Contact qualified ASTA Door technician to evaluate.
<input checked="" type="checkbox"/> When drop testing, door will not descend from header.	Too much tension.	If door is under 12' - 0" X 12' - 0", remove 1/2 turn of tension and perform drop test again. If door is greater than 12' - 0" X 12' - 0" consult factory.





To insure proper identification of this door please complete the information below.

Door Model: \_\_\_\_\_

Door Size: \_\_\_\_\_ x \_\_\_\_\_

Serial Number : \_\_\_\_\_

Installed By: \_\_\_\_\_ Installation Date: \_\_\_\_\_

## LIMITED WARRANTY

### Commercial Rolling Steel Doors

ASTA Door Corporation warrants rolling steel doors, shutters and components to be free from defects in materials and workmanship for a period of five (5) years. Spring wire is warranted for one year. All warranty periods begin with the date of manufacture. ASTA obligations are strictly limited to repair or replacement of defective parts and components during the warranty period.

This limited warranty excludes: (1) rust caused by damages or scratching; (2) damage resulting from exposure to corrosive chemicals, corrosive fumes, condensation, water or fire; (3) damages caused by accident, improper use, negligent operation, improper installation, improper maintenance or normal wear; (4) shipping, installation or labor charges; (5) defects in paints or coatings used to finish door sections; (6) any product or component which is modified, altered, or not part of the original door, and (7) damages resulting from any circumstances beyond the direct control of ASTA Door Corporation.

In the event of a defective component, contact the dealer the door was purchased from within fifteen (15) days from discovery of the defect. ASTA reserves the right to inspect all products alleged to be defective and to verify eligibility of this limited warranty.

**THIS LIMITED WARRANTY EXCLUDES ANY LOSS OR DAMAGE NOT SPECIFICALLY UNDERTAKEN HEREIN, INCLUDING, WITHOUT LIMITATION, ANY consequential or incidental damages, such as death, injury, damages to property, or damages arising from loss of use of ANY PRODUCT OR FACILITY. All other warranties, expressed or implied, including any warranties of fitness for a PARTICULAR PURPOSE and of merchantability, are hereby expressly excluded.**

*This warranty is non-transferable.*

