

GUIDE DETAIL AND DIMENSIONS

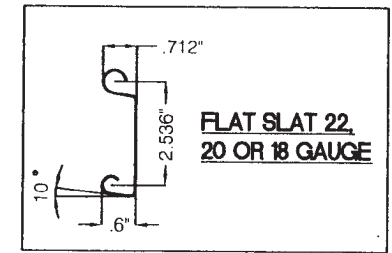

SLIDE BOLT LOCK ONE @ EACH JAMB

SIDE ELEVATION

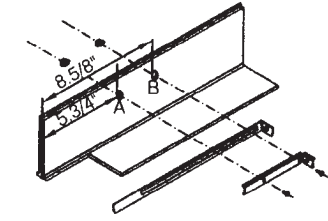
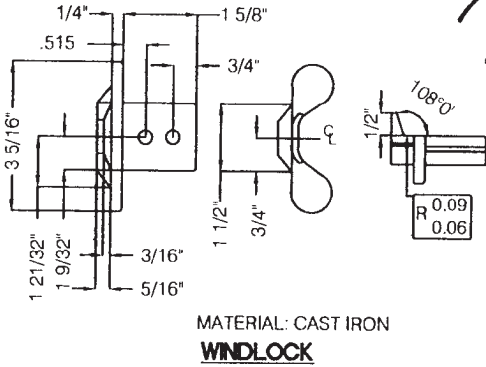
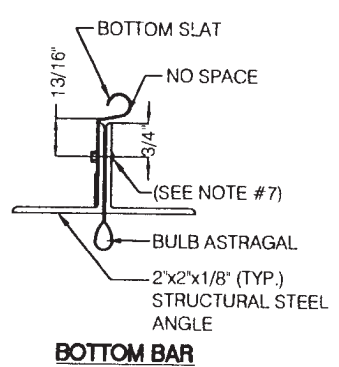

J. H. Dixon, Jr.
8/24/12

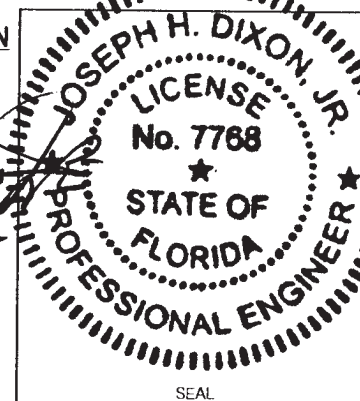

ASTA
ASTA Door Corporation
4255 McEver Industrial Dr.
Acworth, GA 30101
PH: (770) 924-2600/Fax: (770) 974-1455
www.astadoor.com

400 SERIES FLAT SLAT CERTIFIED WINDLOAD AND IMPACT RATED ROLLING STEEL SERVICE DOOR

SCALE : VARIES (DO NOT SCALE DRAWINGS)

TOLERANCES
FRACTION = +/- 1/32
.X = +/- .032
.XX = +/- .015
.XXX = +/- .005 < +/- .5

DRAWN BY: BCLLC
ISSUE: 08-23-12

TEST SIZE 18'-6"W x 10'H	DESIGN PRESSURE +/- 65.0	TEST PRESSURE +/- 82.5
MODELS 422FIM-22 GAUGE 420FIM-20 GAUGE 418FIM-18 GAUGE	TEST LOCATION ELEMENT-ORLANDO 124 PREMIER ROAD ORLANDO, FL 32822	
TEST REPORT # ESP010181P TEST DATES: 6/18/12 - 6/21/12		

Summary of Welded Jamb Connections
E-Guide to Steel Jamb

Series	Door ID	Slat gage	Tested Door* 16'-6" wide	Design Wind Load		Job No.	slip in	P1pf catenary plf	P1nf catenary plf	Slot size	all weld spacings are maximums***			
				Pos psf	Neg psf						Weld in Slot Only		Weld in Slot plus Fillet Weld at Toe	
											min. 3/16" jamb in slot only	3/16" jamb in slot	3/16" jamb at toe	
1/4" Standard Wall Angle											slot and toe welds staggered			
400	418FIM	18		55.0	55.0	32022	0.625	2000	2000	9/16" x 3/4"	1/4" fillet weld**	1/4" fillet weld**	1/4 x 1-1/2	
	420FIM	20		55.0	55.0	"	0.625	2000	2000	9/16" x 3/4"	12" o.c.	12" o.c.	12" o.c.	
	422FIM	22	Test	55.0	55.0	"	0.625	2000	2000	9/16" x 3/4"				
600	618IM	18		50.0	45.0	32022	0.625	1881	1663	9/16" x 3/4"	1/4" fillet weld**	1/4" fillet weld**	1/4 x 1-1/2	
	620IM	20		50.0	45.0	"	0.625	1881	1663	9/16" x 3/4"	12" o.c.	12" o.c.	12" o.c.	
	622IM	22	Test	50.0	45.0	"	0.625	1881	1663	9/16" x 3/4"				

* doors tested with 1/2" bolts @ 12" o.c. connecting to 3/16" steel jamb per drawing

** fillet weld around full perimeter of slot

*** no spacings exceed the fastener spacing of the test

GENERAL NOTES:

- STEEL USED FOR SLATS IS ASTM-A653 WITH MINIMUM YIELD OF 50 KSI AND TENSILE OF 60 KSI.
- GUIDES COMPOSED OF STRUCTURAL STEEL ANGLES WITH MINIMUM .1875" THICKNESS.
- THE WINDLOCKS ARE ATTACHED TO EVERY OTHER SLAT BEGINNING AT THE BOTTOM SLAT. WINDLOCKS ARE ATTACHED USING TWO - 1/4" x 15/32" STEEL, ZINC PLATED RIVETS.
- THIS DOOR HAS BEEN DESIGNED AND TESTED IN ACCORDANCE WITH THE FLORIDA BUILDING CODE AND THE INTERNATIONAL BUILDING CODE. THE DESIGN WIND PRESSURES REQUIRED FOR ANY DOOR SHALL BE DETERMINED USING THE APPROPRIATE SECTION OF THE CODE HAVING JURISDICTION WHERE THE BUILDING IS LOCATED.
- THIS DOOR HAS BEEN SUCCESSFULLY TESTED TO:
 - THE UNIFORM STATIC AIR PRESSURE TEST PER ASTM E-330 AND ANSI/DASMA 108 TO A DESIGN LOAD OF +/- 55.0PSF
 - THE LARGE MISSILE IMPACT TEST PER TAS 201 AND ANSI/DASMA 115 WITH THE IMPACT DIRECTION TOWARD THE EXTERIOR FACE OF THE SLATS.
 - THE CYCLIC WIND PRESSURE TEST PER TAS 203 AND ANSI/DASMA 115.
- REFERENCE ELEMENT-ORLANDO, TEST REPORT #ESP010181P, TESTING DATES: 6/18/12 - 6/21/12.
- BOTTOM BAR ASSEMBLY FASTENED 5 3/4" FROM EACH END AND 12" O.C. FROM CENTER USING 5/16" x 1" CARRIAGE BOLTS.

8/24/12

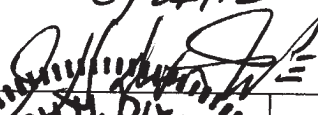

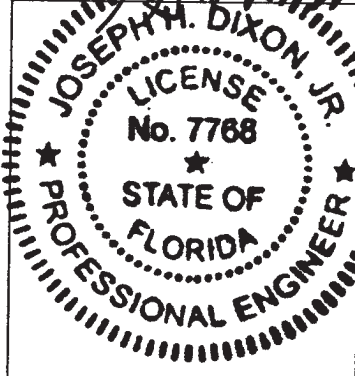

SEAL



4255 McEver Industrial Dr.
Acworth, GA 30101
PH: (770) 924-2600/Fax: (770) 974-1455
www.astadoor.com

**400 SERIES FLAT SLAT CERTIFIED
WINDLOAD AND IMPACT
RATED ROLLING STEEL SERVICE
DOOR**

SCALE : VARIES (DO NOT SCALE DRAWINGS)	TEST SIZE 16'-6" W x 10' H	DESIGN PRESSURE +/- 55.0	TEST PRESSURE +/- 82.5
TOLERANCES FRACTION = +/- 1/32 .X = +/- .032 .XX = +/- .015 .XXX = +/- .005 < +/- .5	MODELS 422FIM-22 GAUGE 420FIM-20 GAUGE 418FIM-18 GAUGE	TEST LOCATION ELEMENT-ORLANDO 124 PREMIER ROAD ORLANDO, FL 32822 TEST REPORT #ESP010181P TEST DATES: 6/18/12 - 6/22/12	
DRAWN BY: BCLLC ISSUE: 08-23-12	DRAWING #607-5-400FIM		SHEET 2 OF 2